



Imagen: Moto exclusivamente para competición y circuito cerrado.
Picture: Motorcycle only for competition and closed circuit.



 **MANUAL DE DESPIECE**

NEUTRA K3

 **PARTS BOOK**

NEUTRA K3

/2025



Esta publicación incluye la última información de la motocicleta disponible antes de su publicación. NEUTRA se reserva el derecho a realizar cambios en cualquier momento sin previo aviso y sin contraer ningún tipo de obligación. Podrá encontrar los recambios y accesorios en nuestra red de concesionarios (www.neutramotor.com).

This publication includes the latest information about the motorcycle available at the time of release. NEUTRA reserves the right to make changes at any time without prior notice and without incurring any obligation. You can find spare parts and accessories at our dealer network (www.neutramotor.com).

INSTRUCCIONES DE USO DEL CATÁLOGO DE RECAMBIOS	3
SEC 01: Suspensión delantera	4
SEC 02: Manillar	5
SEC 03: Bastidor	6 - 7
SEC 04: Basculante	8
SEC 05: Motor	9
SEC 06: Electrónica	10
SEC 07: Instalación eléctrica	11
SEC 08: Rueda delantera	12
SEC 09: Rueda trasera	13
SEC 10: Freno delantero	14
SEC 11: Freno trasero	15
SEC 12: Plásticos	16
SEC 13: Adhesivos advertencia	17
SEC 14: Adhesivos NEUTRA K3	18
SEC 15: Accesorios	19 - 22

USAGE INSTRUCTIONS FOR THE SPARE PARTS CATALOG	3
SEC 01: Front Suspension	4
SEC 02: Handlebar	5
SEC 03: Frame	6 - 7
SEC 04: Swingarm	8
SEC 05: Engine	9
SEC 06: Electronics	10
SEC 07: Electrical Installation	11
SEC 08: Front Wheel	12
SEC 09: Rear Wheel	13
SEC 10: Front Brake	14
SEC 11: Rear Brake	15
SEC 12: Plastics	16
SEC 13: Warning Labels	17
SEC 14: NEUTRA K3 Labels	18
SEC 15: Accessories	19 - 22

INSTRUCCIONES

INSTRUCTIONS

INSTRUCCIONES DE USO DEL CATÁLOGO DE RECAMBIOS

Este catálogo de despiece se debe utilizar para pedir piezas de recambio. Contiene todas las piezas del modelo NEUTRA K3.

1) CÓMO PEDIR PIEZAS

Los pedidos de piezas de recambio deben contener:

- Cantidad de piezas a solicitar.
- REFERENCIA indicada en el manual.

Observaciones: En la columna CANTIDAD se indica la cantidad de piezas de la referencia.

2) ABREVIATURAS

En este catálogo de despiece se usan las siguientes abreviaturas:

- Ø Diámetro
- L Izquierdo
- R Derecho
- M (M5) Métrico (Métrico 5 mm)
- Z (Z 36) Dientes (36 dientes)

3) NUMERACIÓN DE SERIE

En la parte derecha de la Pipa de Dirección:

- **MODELO** **K3**
- **Nº BASTIDOR** *****
- **TIPO** **FACTORY: N01S CLUB: N02S**

USAGE INSTRUCTIONS FOR THE SPARE PARTS CATALOG

This parts catalog should be used to order replacement parts. It contains all the parts for the NEUTRA K3 model.

1) HOW TO ORDER PARTS

Spare parts orders must include:

- Quantity of parts to order.
- REFERENCE indicated in the manual.

Notes: The QUANTITY column indicates the number of parts for each reference.

2) ABBREVIATIONS

The following abbreviations are used in this parts catalog:

- Ø Diameter
- L Left
- R Right
- M (M5) Metric (Metric 5 mm)
- Z (Z 36) Teeth (36 teeth)

3) SERIAL NUMBERING

On the right side of the Steering Stem:

- **MODEL** **K3**
- **FRAME N.º** *****
- **TYPE** **FACTORY: N01S CLUB: N02S**

SEC 01
**SUSPENSIÓN
DELANTERA**
**FRONT
SUSPENSION**

Nº	REF.	DESCRIPCIÓN	PARTS NAME	QTY
1	N01S-03-21	JUEGO DE RODAMIENTOS DE DIRECCIÓN	BEARING HEAD SET	1
2	N01S-03-27	ARAÑA DE JUEGO DE RODAMIENTOS	HEAD SET EXPANDER	1
3	N01S-05-01	SUSPENSIÓN DELANTERA DE AIRE	FRONT AIR SUSPENSION FORK	1
3-A	N01S-05-01-M2	SUSPENSIÓN DELANTERA DE MUELLE (N02S)	SPRING FRONT SUSPENSION FORK (N02S)	1
4	N01S-05-03	POTENCIA GRADUABLE	ADJUSTABLE FIXING HANDLEBAR	1
5	N01S-05-04	TIJA INFERIOR	LOWER CLAMP	1
6	N01S-05-14	TIJA SUPERIOR	TOP CLAMP	1
7	N01S-07-11-PN	SOPORTE DEL GUARDABARROS DELANTERO	FRONT MUDGUARD SUPPORT	1
8	N01S-07-12	REMACHE Ø4	RIVET Ø4	1
9	N01S-12-23	GUÍA DE MANGUERA DE FRENO DELANTERO	FRONT BRAKE HOSE GUIDE	1
10	N01S-90-01	BRIDA SUJECIÓN 3,5x140 (NEGRA)	TIE BAND 3.5x140 (BLACK)	5
11	90125-0400008ZB	ARANDELA DIN 125 M4 ZB	WASHER DIN 125 M4 ZB	1
12	90912-0502008ZN	TORNILLO DIN 912 M5x20 ZN	SCREW DIN 912 M5x20 ZN	4
13	90912-0602008ZN	TORNILLO DIN 912 M6x20 ZN	SCREW DIN 912 M6x20 ZN	4
14	90912-0607508ZB	TORNILLO DIN 912 M6x75 ZB	SCREW DIN 912 M6x75 ZB	1
15	90917-0600008IN	TUERCA DIN 917 M6 INOX	NUT DIN 917 M6 INOX	1
16	96921-0601208ZB	TORNILLO DIN 6921 M6x12 ZB	SCREW DIN 6921 M6x12 ZB	1
17	96923-0500008ZB	TUERCA DIN 6923 M5 ZB	NUT DIN 6923 M5 ZB	1
18	97382-0501008ZB	TORNILLO ISO 7380-2 M5x10 ZB	SCREW ISO 7380-2 M5x10 ZB	1

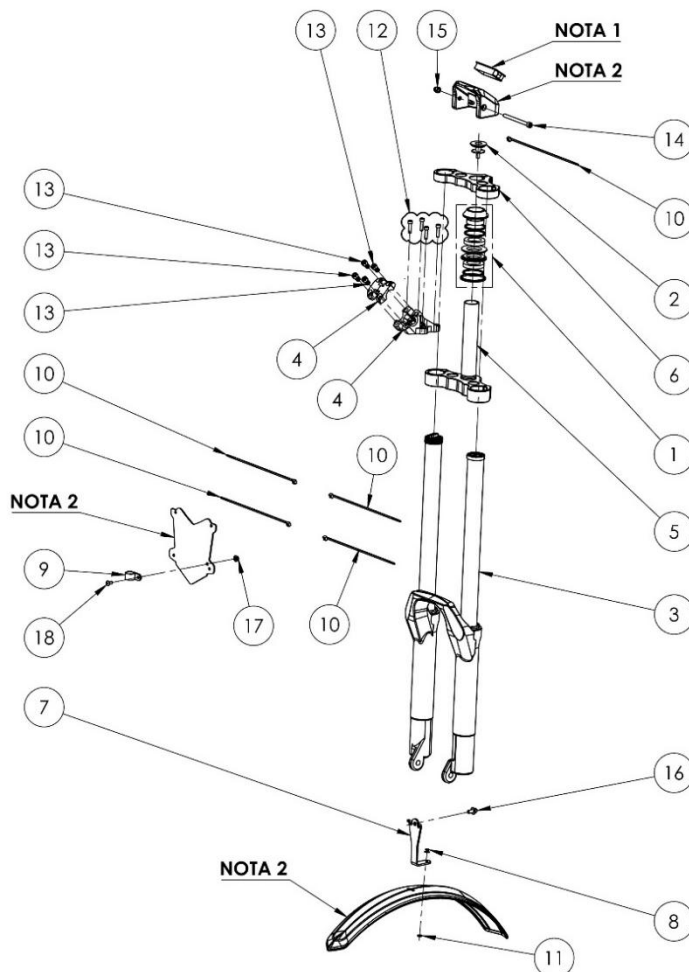

NOTA 1: VER EN PÁGINA 10 / NOTE 1: SEE ON PAGE 10
 NOTA 2: VER EN PÁGINA 16 / NOTE 2: SEE ON PAGE 16

SEC 02
MANILLAR
HANDLEBAR

Nº	REF.	DESCRIPCIÓN	PARTS NAME	QTY
1	N01S-03-22	TAPÓN DEL MANILLAR	HANDELBAR CAP	2
2	N01S-05-02	MANILLAR 640x3MM	HANDLEBAR 640x3 mm	1
3	N01S-05-07-MC	CONJUNTO MECANISMO DE GAS	ASSY THROTTLE BODY	1
4	N01S-05-08-MC	CAÑA DE GAS	THROTTLE ROD	1
5	N01S-05-09-M2	CABLE DE GAS	CABLE COMP THROTTLE	1
6	N01S-05-12-MC	EMPUÑADURA DERECHA	GRIP HANDLE R	1
7	N01S-05-13-MC	EMPUÑADURA IZQUIERDA	GRIP HANDLE L	1
8	N01S-90-01	BRIDA DE SUJECIÓN 3,5x140 (NEGRA)	TIE BAND 3,5x140 (BLACK)	1

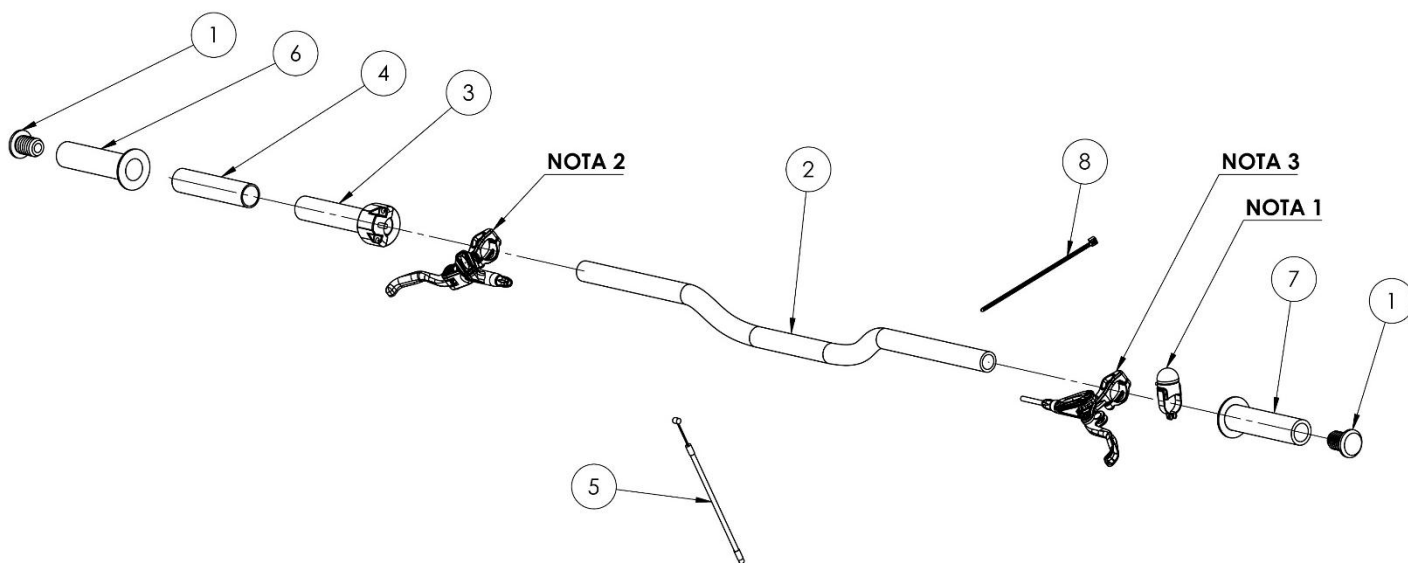

NOTA 1: VER EN PÁGINA 10 / NOTE 1: SEE ON PAGE 10

NOTA 2: VER EN PÁGINA 14 / NOTE 2: SEE ON PAGE 14

NOTA 3: VER EN PÁGINA 15 / NOTE 3: SEE ON PAGE 15

SEC 03
BASTIDOR
FRAME BODY

Nº	REF.	DESCRIPCIÓN	PARTS NAME	QTY
1	N01S-01-11-VE	CORREA DE VELCRO FIJACIÓN BATERÍA	VELCRO STRAP FIX BATTERY	1
2	N01S-02-14	BOÓN POTENCIÓMETRO DE MAPAS	PROGRAM KNOB	1
3	N01S-03-01-PP	BASTIDOR	FRAME BODY SET	1
4	N01S-03-05	SOPORTE TRASERO CHASIS A PLACA PROTECTORA	REAR SUPORT FRAME BODY TO SKID PLATE	1
5	N01S-03-06	CHASIS LATERAL DERECHO	SIDE FRAME R	1
6	N01S-03-07	CHASIS LATERAL IZQUIERDO	SIDE FRAME L	1
7	N01S-03-08-ZB	SOPORTE DELANTERO IZQUIERDO FIJACIÓN PLACA PROTECTORA	STAY FRONT L FIX PLATE SKID	1
8	N01S-03-09	PLACA PROTECTORA	PLATE SKID	1
9	N01S-03-10-ZB	SOPORTE COMPLETO AMORTIGUADOR	SHOCKABSORBER STAY COMP	1
10	N01S-03-11	BARRA DE BATERÍA	BATTERY BAR	1
11	N01S-03-12-ZB	SOPORTE ESTRIBO	BRACKET STEP	2
12	N01S-03-14	ESTRIBO DERECHO	STEP R	1
13	N01S-03-15	ESTRIBO IZQUIERDO	STEP L	1
14	N01S-03-20	ARANDELA ESTRIBO D8	WASHER STEP D8	4
15	N01S-03-23	TUBO DE SILICONA	SILICONE PIPE	1
16	N01S-03-24-ZB	SOPORTE DELANTERO DERECHO FIJACIÓN PLACA PROTECTORA	STAY FRONT R FIX PLATE SKID	1
17	N01S-03-25	PROTECCIÓN TUBO DE SILICONA CHASIS	SILICONE PIPE FRAME PROTECTION	1
18	N01S-03-26	GOMA CENTRADORA CAJA BATERÍA	BATTERY BOX CENTERING RUBBER	2
19	N01S-03-33	SILENTBLOCK TOPE BASCULANTE	SWINGARM STOP SILENTBLOCK	1
20	N01S-03-34	TORNILLO TOPE BASCULANTE	SWING STOP SCREW	1
21	N01S-04-21	CASQUILLO MOTOR CHASIS - CHASIS LATERAL L=19MM	ENGINE COLLAR FRAME - SIDE FRAME L=19MM	2
22	N01S-06-20	ADHESIVO FIJACIÓN INSTALACIÓN	FIXATIVE INSTALLATION ADHESIVE	4
23	N01S-12-18	TUERCA FIJACIÓN TORNILLO DZUS	NUT FIX BOLT DZUS	1
24	N01S-12-24	GUÍA DE LATIGUILLO FRENO TRASERO	REAR BRAKE HOSE GUIDE	1
25	N01S-12-33	PROTECTOR SUPERIOR DE GOMA INSTALACIÓN ELÉCTRICA	TOP PROTECTOR RUBBER ELECTRICAL INSTALLATION	1
26	N01S-90-02	BRIDA 2,5X98 (NEGRA)	TIE BAND 2,5x98 (BLACK)	7
27	N01S-90-03	BRIDA 3,5X200 (BLANCA)	TIE BAND 3,5x200 (WHITE)	4
28	N01S-90-04	PASADOR SUPERIOR FIJACIÓN DE GOMA ELECTRÓNICA	UPPER ELECTRONIC RUBBER FIXING PIN	1
29	N01S-90-06	ARANDELA BARRA DE BATERÍA	BATTERY BAR WASHER	2
30	90125-0600008ZB	ARANDELA DIN 125 M6 ZB	WASHER DIN 125 M6 ZB	2
31	90125-0800008ZB	ARANDELA DIN 125 M8 ZB	WASHER DIN 125 M8 ZB	1
32	90127-0500008ZB	ARANDELA DIN 127 M5 ZB	WASHER DIN 127 M5 ZB	1
33	90557-0500008ZB	TUERCA DIN 557 M5 ZB	SQUARE NUT DIN 557 M5 ZB	2
34	90912-0501008ZB	TORNILLO DIN 912 M5X10 ZB	SCREW DIN 912 M5X10 ZB	1
35	90912-0604508ZB	TORNILLO DIN 912 M6x45 ZB	SCREW DIN 912 M6X45 ZB	2
36	90912-0804508ZB	TORNILLO DIN 912 M8x45 ZB	SCREW DIN 912 M8X45 ZB	2
37	90985-0600008ZB	TUERCA DIN 985 M6 ZB	NUT DIN 985 M6 ZB	3
38	90985-0800008ZB	TUERCA DIN 985 M8	NUT DIN 985 M8	2
39	96923-0400008ZB	TUERCA DIN 6923 M4 ZB	NUT DIN 6923 M4 ZB	2
40	96923-0500008ZB	TUERCA DIN 6923 M5 ZB	NUT DIN 6923 M5 ZB	1
41	96923-0800008ZB	TUERCA DIN 6923 M8 ZB	NUT DIN 6923 M8 ZB	6
42	97382-0401608ZB	TORNILLO ISO 7380-2 M4X16 ZB	SCREW ISO 7380-2 M4X16 ZB	2
43	97382-0501208ZB	TORNILLO ISO 7380-2 M5X12 ZB	SCREW ISO 7380-2 M5X12 ZB	1
44	97382-0501608ZB	TORNILLO ISO 7380-2 M5x16 ZB	SCREW ISO 7380-2 M5X16 ZB	3
45	97380-08020A2IN	TORNILLO ISO 7380 M8x20 IN	SCREW ISO 7380 M8X20 IN	12
46	97380-08025A2IN	TORNILLO ISO 7380 M8x25 IN	SCREW ISO 7380 M8X25 IN	2
47	97991-0602008ZB	TORNILLO DIN 7991 M6x20 ZB	SCREW DIN 7991 M6X20 ZB	1
48	97991-0602208ZB	TORNILLO DIN 7991 M6x22 ZB	SCREW DIN 7991 M6X22 ZB	1
49	97991-0802508ZB	TORNILLO DIN 7991 M8x25 ZB	SCREW DIN 7991 M8X25 ZB	2
50	99021-0500008ZB	ARANDELA DIN 9021 M5 ZB	WASHER DIN 9021 M5 ZB	1
51	99021-0600008ZB	ARANDELA DIN 9021 M6 ZB	WASHER DIN 9021 M6 ZB	1
52	99021-0800008ZB	ARANDELA DIN 9021 M8 ZB	WASHER DIN 9021 M8 ZB	2

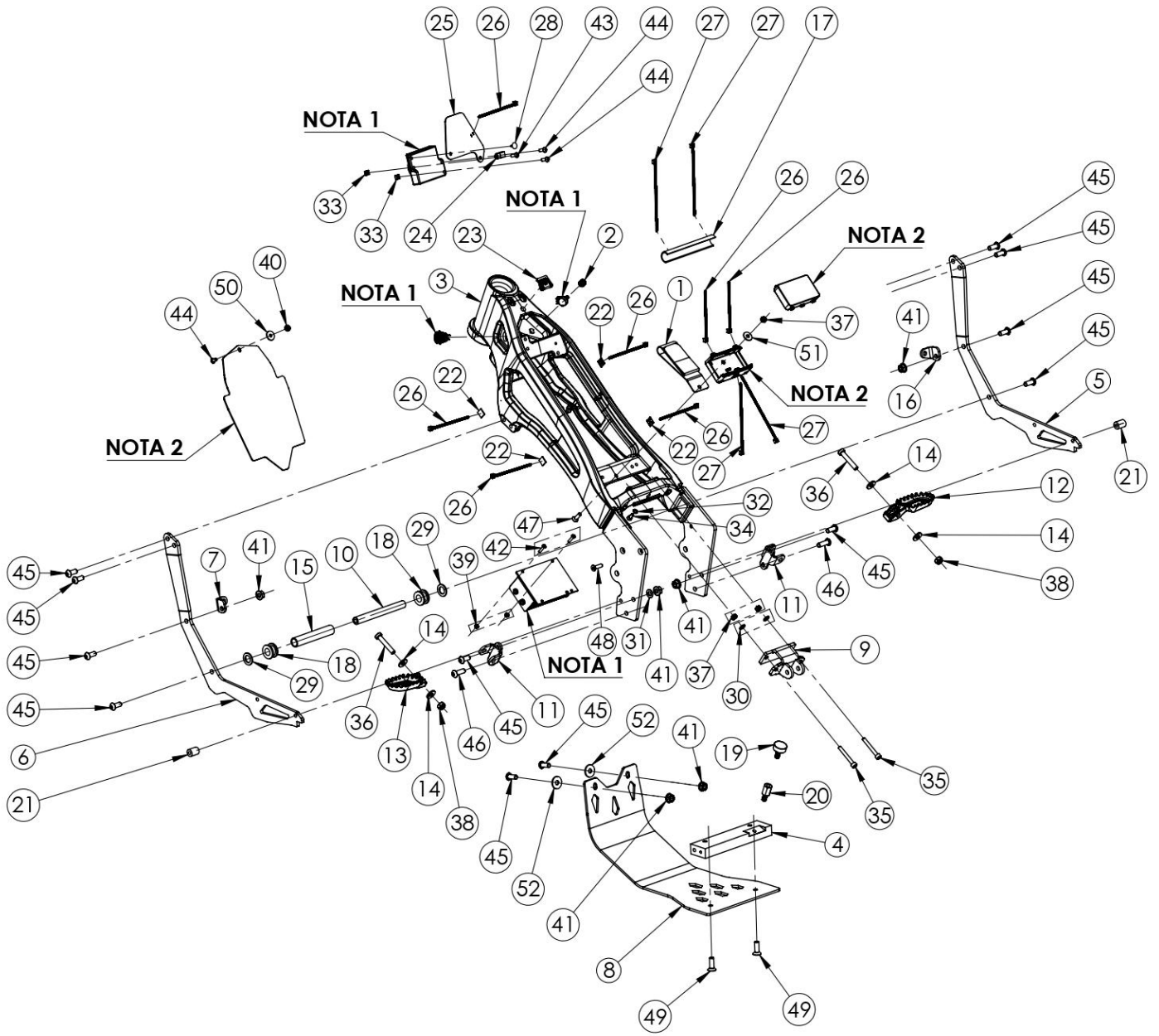

FR.

NOTA 1: VER EN PÁGINA 10 / NOTE 1: SEE ON PAGE 10
NOTA 2: VER EN PÁGINA 16 / NOTE 2: SEE ON PAGE 16

SEC 04
BASCULANTE
SWING ARM

Nº	REF.	DESCRIPCIÓN	PARTS NAME	QTY
1	N01S-06-01-PP	BASCULANTE	SWING ARM	1
2	N01S-06-02	AMORTIGUADOR TRASERO MUELLE	REAR SHOCK ABSORBER SPRING	1
3	N01S-06-04	TAPA EJE BASCULANTE DERECHO	CAP AXLE SWING ARM RH	1
4	N01S-06-05	RODAMIENTO DE AGUJAS HK 1512	BEARING NEEDLE HK 1512	1
5	N01S-06-06	RETÉN DE POLVO 15X21X3	DUST SEAL 15X21X3	4
6	N01S-06-07	RODAMIENTO DE AGUJAS HK 1516	BEARING NEEDLE HK 1516	1
7	N01S-06-09-ZB	CONJUNTO TENSOR CADENA	CHAIN TENSIONER ASSEMBLY	1
8	N01S-06-10	ESPACIADOR GOMA TENSOR CADENA	RUBBER SLIPER CHAIN SPACER	1
9	N01S-06-11	GOMA TENSOR CADENA	RUBBER SLIPER CHAIN	1
10	N01S-06-15	CASQUILLO EJE BASCULANTE IZQUIERDO	CAP AXLE SWING ARM LH	1
11	N01S-06-16	CASQUILLO INTERIOR TENSOR CADENA	CHAIN TENSIONER INNER COLLAR	1
12	N01S-06-19	MUELLE TENSOR DE CADENA	SPRING TENSIONER CHAIN	1
13	N01S-06-22	CABALLETE NEUTRA 20"	SIDE STAND NEUTRAL 20"	1
14	N01S-06-23	MUELLE CABALLETE	SPRING SIDE STAND	1
15	N01S-06-24-ZB	SOPORTE CABALLETE	SIDE STAND STAY	1
16	N01S-06-25-ZB	SOPORTE MUELLE CABALLETE	BRACKET SPRING SIDE STAND	1
17	N01S-12-24	GUÍA DE MANGUERA DE FRENO TRASERO	REAR BRAKE HOSE GUIDE	1
18	N01S-90-05	TAPÓN BASCULANTE	SWING ARM CAP	3
19	90125-1400008ZB	ARANDELA DIN 125 M14 ZB	WASHER DIN 125 M14 ZB	2
20	90912-0501008ZB	TORNILLO DIN 912 M5x10 ZB	SCREW DIN 912 M5x10 ZB	2
21	90912-0804010ZB	TORNILLO DIN 912 M8x40 ZB	SCREW DIN 912 M8x40 ZB	1
22	90912-0804510ZB	TORNILLO DIN 912 M8x45 ZB	SCREW DIN 912 M8x45 ZB	1
23	90985-0800000ZB	TUERCA DIN 985 M8	NUT DIN 985 M8	1
24	96923-0800008ZB	TUERCA DIN 6923 M8 ZB	NUT DIN 6923 M8 ZB	2
25	97382-0402008ZB	TORNILLO ISO 7380-2 M4x20 ZB	SCREW ISO 7380-2 M4x20 ZB	2
26	97382-0501008ZB	TORNILLO ISO 7380-2 M5x10 ZB	SCREW ISO 7380-2 M5x10 ZB	4
27	97380-0802008IN	TORNILLO ISO 7380 M8x20 IN	SCREW ISO 7380 M8x20 IN	3
28	97380-0802508IN	TORNILLO ISO 7380 M8x25 IN	SCREW ISO 7380 M8x25 IN	1
29	97382-10030A2IN	TORNILLO ISO 7380-2 M10x30 TORX INOX	SCREW DIN 7380-2 M10x30 TORX INOX	2
30	N01S-90-05-MC	TAPÓN BASCULANTE MC	SWINGARM CAP MC	1
31	97382-0501608ZB	TORNILLO ISO 7380-2 M5x16 ZB	SCREW ISO 7380-2 M5x16 ZB	1

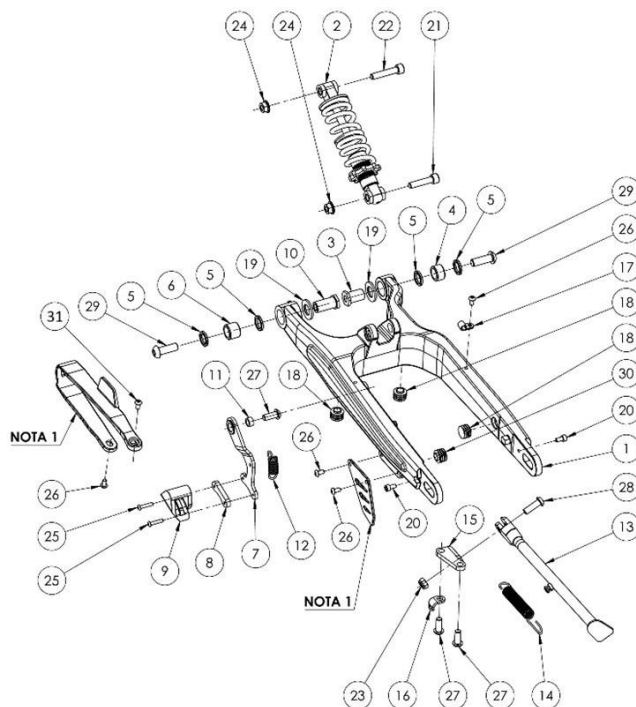
FR.
NOTA 1: VER EN PÁGINA 16 / NOTE 1: SEE ON PAGE 16

SEC 05
MOTOR
MOTOR

Nº	REF.	DESCRIPCIÓN	PARTS NAME	QTY
1	N01S-04-01	MOTOR	MOTOR	1
2	N01S-04-02	PIÑÓN Z11 MOTOR ELÉCTRICO	SPROCKET Z11 ELECTRIC ENGINE	1
3	N01S-04-03	CADENA DE TRANSMISIÓN	CHAIN DRIVE	1
4	N01S-04-04	ENGANCHE CADENA DE TRANSMISIÓN	JOINT CHAIN DRIVE	1
5	N01S-04-19	CASQUILLO MOTOR IZQUIERDO - L=13MM	ENGINE COLLAR L - L=13MM	2
6	N01S-04-20	CASQUILLO MOTOR DERECHO - L=6MM	ENGINE COLLAR R - L=6MM	2
7	N01S-04-21	CASQUILLO MOTOR BASTIDOR - LATERAL BASTIDOR L=19MM	ENGINE COLLAR FRAME - SIDE FRAME L=19MM	2
8	N01S-04-22	CASQUILLO MOTOR BASTIDOR DERECHO - L=31MM	ENGINE COLLAR FRAME R - L=31MM	1
9	N01S-04-23	CASQUILLO MOTOR BASTIDOR IZQUIERDO - L=38MM	ENGINE COLLAR FRAME L - L=38MM	1
10	90125-0600008ZB	ARANDELA DIN 125 M6 ZB	WASHER DIN 125 M6 ZB	4
11	90912-0503508ZN	TORNILLO DIN 912 M5x35 ZN	SCREW DIN 912 M5x35 ZN	2
12	90912-0602008ZB	TORNILLO DIN 912 M6x20 ZB	SCREW DIN 912 M6x20 ZB	1
13	90912-0602508ZB	TORNILLO DIN 912 M6x25 ZB	SCREW DIN 912 M6x25 ZB	2
14	90912-0604008ZB	TORNILLO DIN 912 M6x40 ZB	SCREW DIN 912 M6x40 ZB	2
15	90912-0606008ZB	TORNILLO DIN 912 M6x60 ZB	SCREW DIN 912 M6x60 ZB	1
16	90912-0607008ZB	TORNILLO DIN 912 M6x70 ZB	SCREW DIN 912 M6x70 ZB	1
17	97349-0600010ZB	ARANDELA DIN 7349 M6 ZB	WASHER DIN 7349 M6 ZB	1
18	97991-0606008ZB	TORNILLO DIN 7991 M6x60 ZB	SCREW DIN 7991 M6x60 ZB	1
19	97991-0607008ZB	TORNILLO DIN 7991 M6x70 ZB	SCREW DIN 7991 M6x70 ZB	1

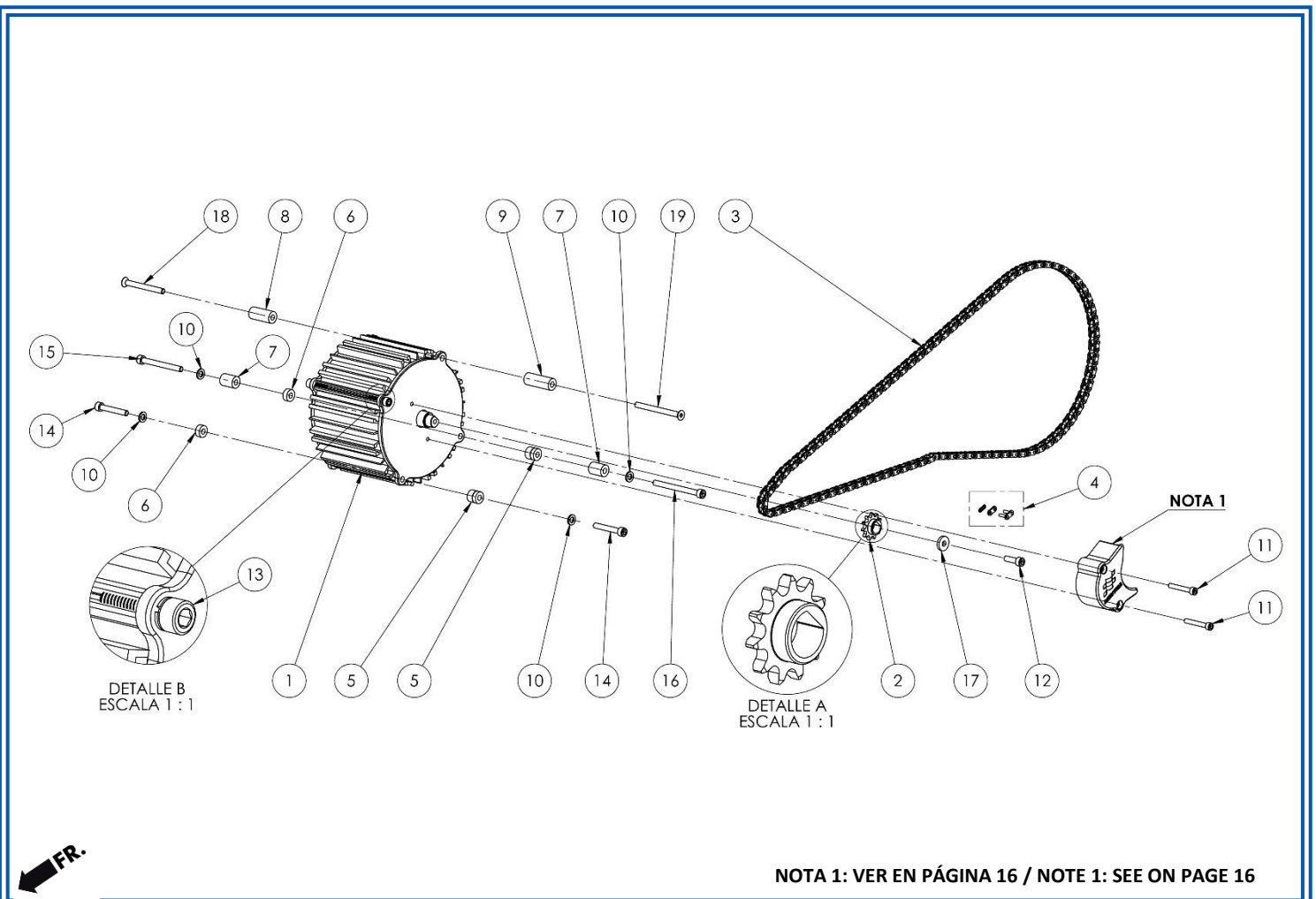

SEC 06
ELECTRÓNICA
ELECTRONICS

Nº	REF.	DESCRIPCIÓN	PARTS NAME	QTY
1	N01S-01-01	BATERÍA STD (50,4V 16,8Ah)	BATTERY STD (50,4V 16,8Ah)	1
1-A	N01S-01-61	BATERÍA COMPACTA (50,4V 12,6Ah) (N02S)	COMPACT BATTERY (50,4V 12,6Ah) (N02S)	1
2	N01S-02-01-MC	CONTROLADORA 48V	CONTROLLER 48V	1
3	N01S-02-04	CARGADOR DC 51V 5A	CHARGER DC 51V 5A	1
4	N01S-02-06	POTENCIÓMETRO MAPAS	MAPS POTENTIOMETER	1
5	N01S-02-07	HOMBRE AL AGUA	MAGNETIC KILL BUTTON	1
6	N01S-02-09	INDICADOR DE BATERÍA	BATTERY INDICATOR	1
7	N01S-02-10	INTERRUPTOR ON/OFF	SWITCH ON/OFF	1
8	N01S-02-11	RELÉ 100A 48V	RELAY 100A 48V	1
9	N01S-05-10	CONTROL DE GAS	GAS CONTROL	1
10	N01S-12-36	ESPIRAL INSTALACIÓN CONTROLADORA 8MM	SPIRAL HOSE CONTROLLER INSTALLATION 8MM	1
11	N01S-12-37	ESPIRAL INSTALACIÓN MOTOR 12MM	SPIRAL HOSE ENGINE INSTALLATION 12MM	1

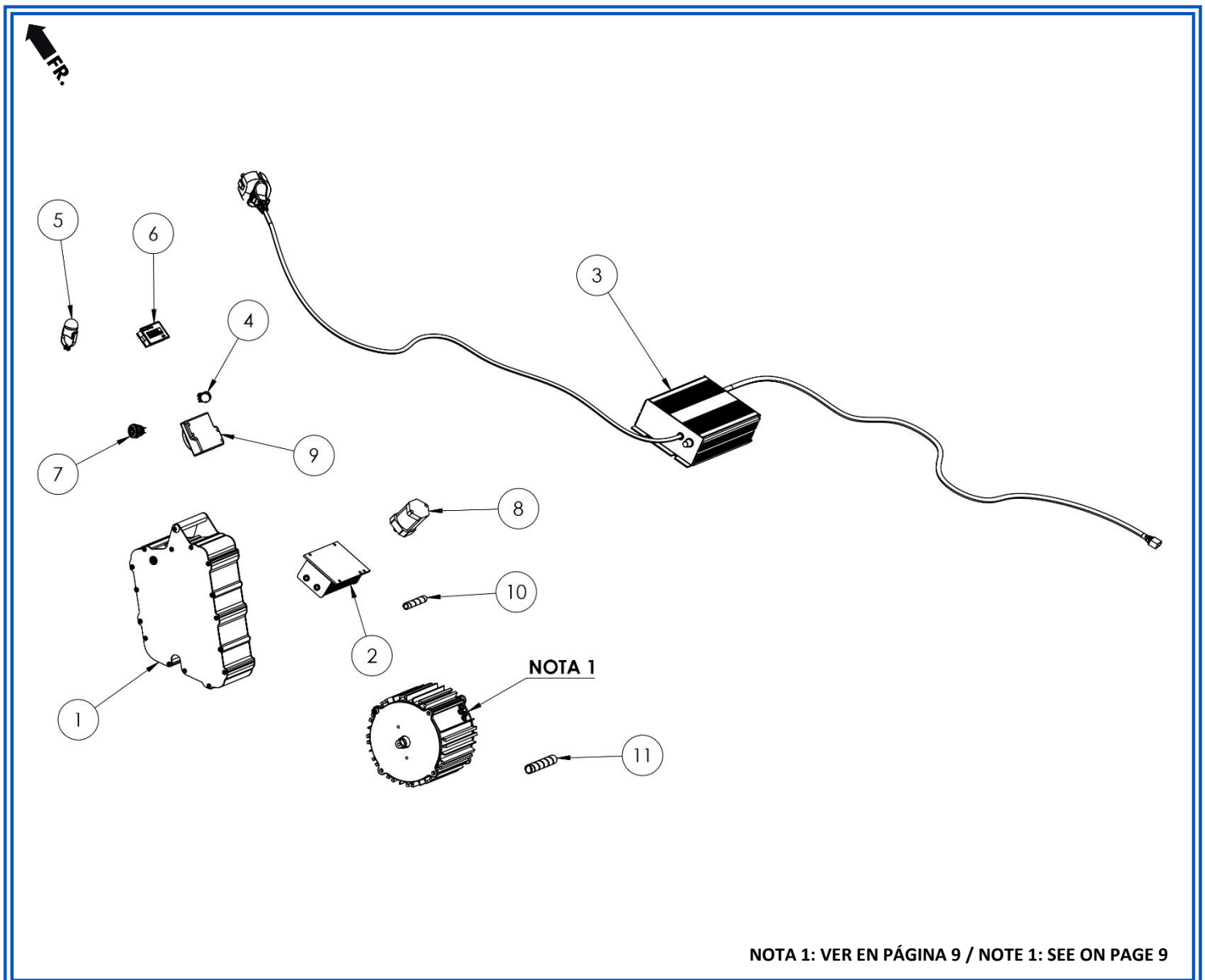

SEC 07	INSTALACIÓN ELÉCTRICA	ELECTRICAL INSTALLATION
---------------	------------------------------	--------------------------------

Nº	REF.	DESCRIPCIÓN	PARTS NAME	QTY
1	N01S-02-02	INSTALACIÓN ELÉCTRICA BATERÍA	BATTERY ELECTRICAL INSTALLATION	1
2	N01S-02-03	INSTALACIÓN ELÉCTRICA PRINCIPAL	MAIN ELECTRICAL INSTALLATION	1
3	N01S-02-12	INSTALACIÓN ELÉCTRICA FUSIBLE	FUSE ELECTRICAL INSTALLATION	1
4	N01S-02-13	INSTALACIÓN ELÉCTRICA RESISTENCIA	RESISTOR ELECTRICAL INSTALLATION	1
5	N01S-02-15	INSTALACION ELECTRICA POTENCIOMETRO MAPAS	ELECTRICAL INSTALLATION MAP SELECTOR POTENTIOMETER	1
6	N01S-02-17	CINTA HOMBRE AL AGUA	KILL BUTTON TETHER	1

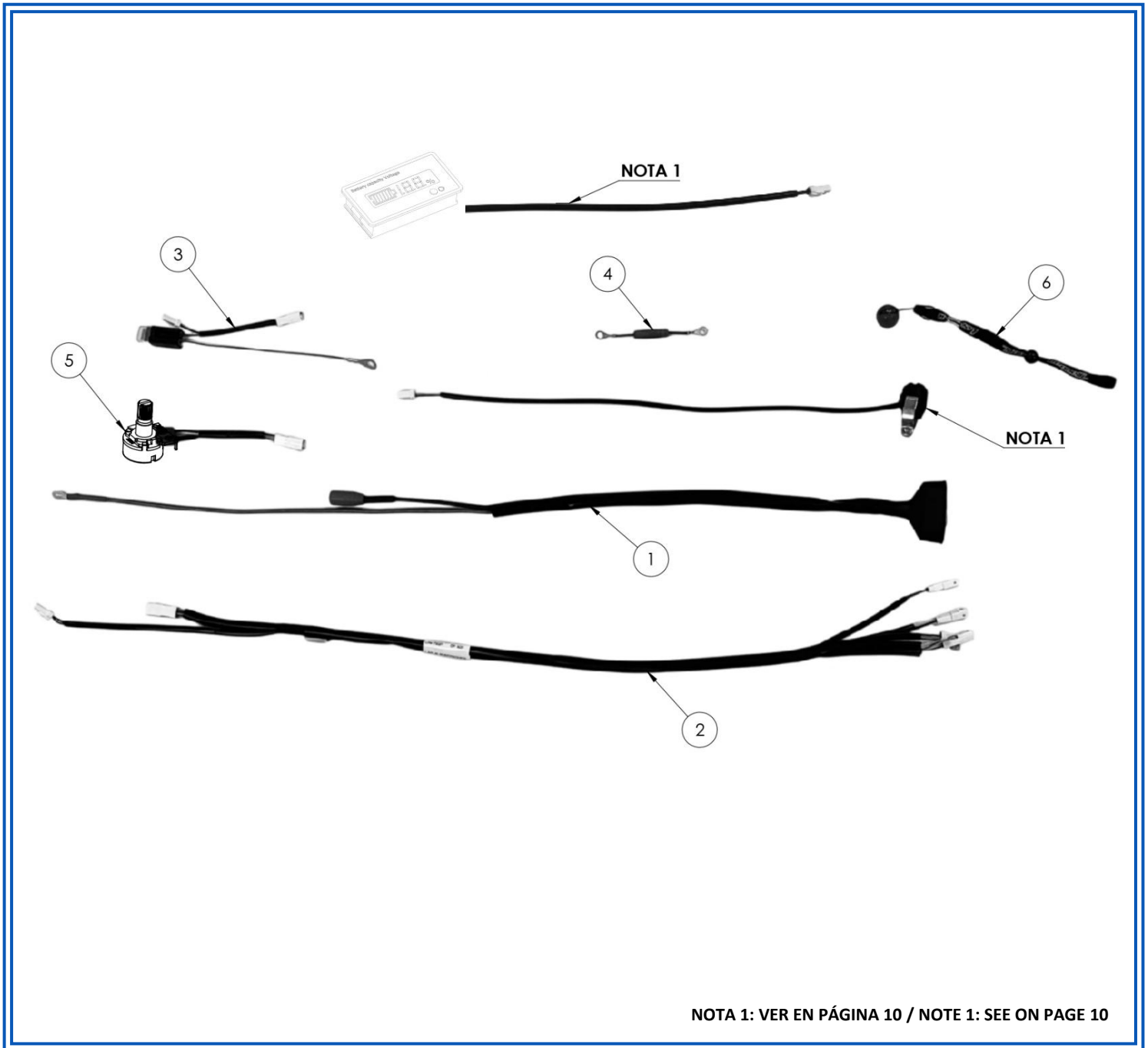

NOTA 1: VER EN PÁGINA 10 / NOTE 1: SEE ON PAGE 10

SEC 08
RUEDA DELANTERA
FRONT WHEEL

Nº	REF.	DESCRIPCIÓN	PARTS NAME	QTY
1	N01S-07-02	CONJUNTO DE RUEDA DELANTERA 20"	FRONT WHEEL SET 20"	1
2	N01S-07-04	PROTECCIÓN DE GOMA PARA LLANTA 20"	RUBBER PROTECTION RIM 20"	1
3	N01S-07-05	CÁMARA DE AIRE 20"	INNER TUBE 20"	1
4	N01S-07-06	NEUMÁTICO DELANTERO REBEL 20x2,5	FRONT TYRE REBEL 20x2.5	1
5	N01S-07-07	BUJE DELANTERO	FRONT HUB	1
6	N01S-07-09	RADIO RUEDA DELANTERA 20"	SPOKE - NIPPLE FRONT WHEEL 20"	32
7	N01S-07-01	CONJUNTO LLANTA DELANTERA 20"	FRONT RIM 20" SET	1
8	N01S-07-12	REMACHE Ø4	RIVET Ø4	3
9	N01S-07-14	CASQUILLO PROTECTOR DE DISCO DELANTERO	COLLAR FRONT DISC PROTECTOR	1
10	N01S-07-16	EJE + CASQUILLO BUJE RUEDA DELANTERA	FRONT WHEEL AXLE + BUSHING HUB	1
11	N01S-10-03-PN	SOPORTE PROTECTOR DISCO FRENO DELANTERO	FRONT BRAKE DISC PROTECTOR BRACKET	1
12	N01S-10-08	DISCO DE FRENOS DELANTERO 160	FRONT DISC BRAKE 160	1
13	N01S-12-28	TAPÓN LLANTA	FRONT RIM HOLE CAP	1
14	90125-0400008ZB	ARANDELA DIN 125 M4 ZB	WASHER DIN 125 M4 ZB	3
15	97380-05010A2IN	TORNILLO ISO 7380 M5x10 IN	SCREW ISO 7380 M5x10 IN	6

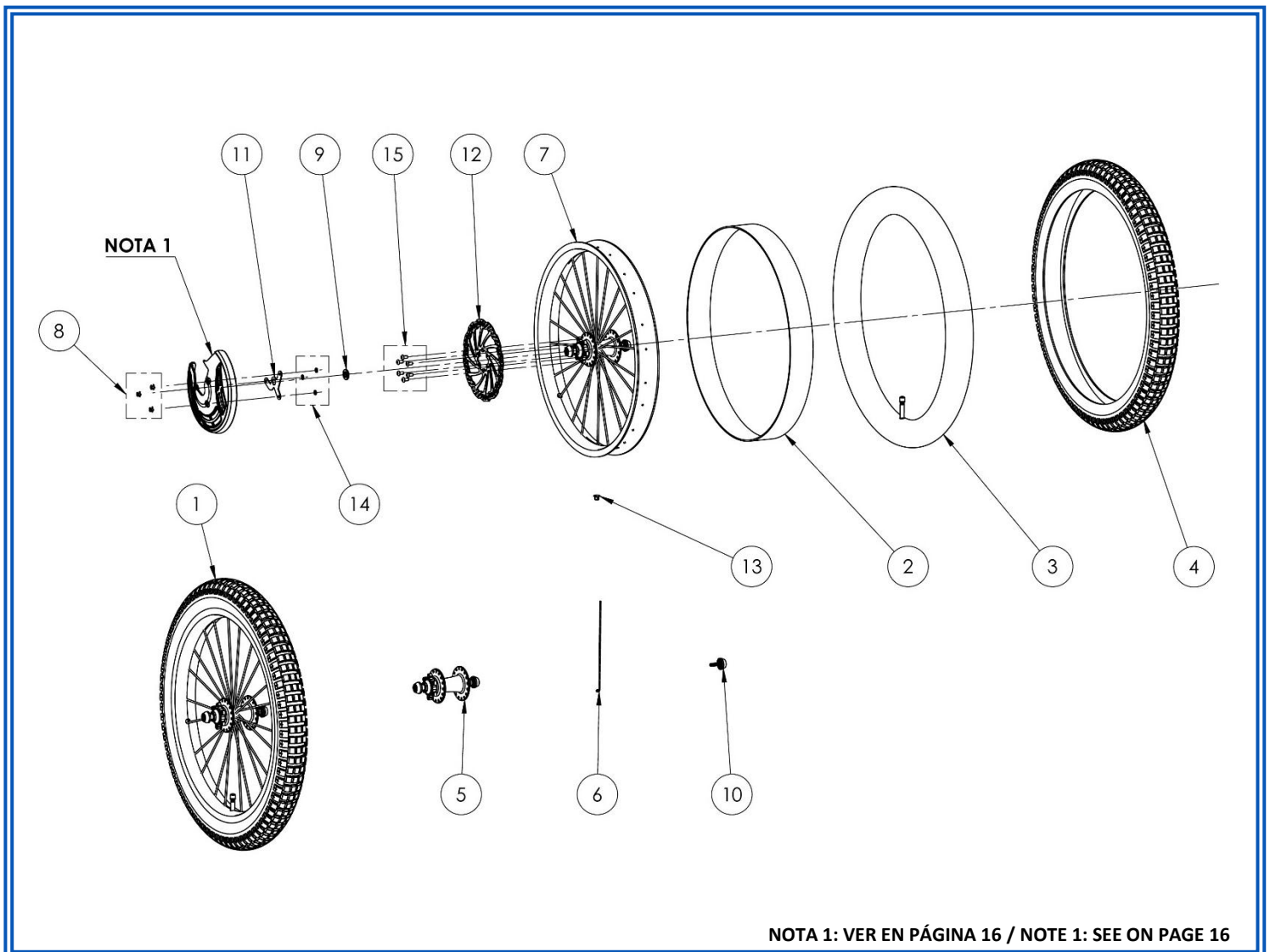

NOTA 1: VER EN PÁGINA 16 / NOTE 1: SEE ON PAGE 16

SEC 09
RUEDA TRASERA
REAR WHEEL

Nº	REF.	DESCRIPCIÓN	PARTS NAME	QTY
1	N01S-07-04	PROTECCIÓN DE GOMA PARA LLANTA 20"	RUBBER PROTECTION RIM 20"	1
2	N01S-07-05	CÁMARA DE AIRE 20"	INNER TUBE 20"	1
3	N01S-08-01	CONJUNTO DE RUEDA TRASERA 20"	REAR WHEEL SET 20"	1
4	N01S-08-02	NEUMÁTICO TRASERO REBEL 20x3,00	REAR TYRE REBEL 20x3,00	1
5	N01S-08-03	PIÑÓN Z90 FINAL CONDUCIDO	SPROCKET Z90 FINAL DRIVEN	1
6	N01S-08-04	EJE DE RUEDA TRASERA	REAR WHEEL AXLE	1
6-A	90931-1219010ZB	TORNILLO DIN 931 M12x190 ZB (N02S)	SCREW DIN 912 M6x15 ZN (N02S)	1
7	N01S-08-05-AP	AJUSTADOR DE CADENA	CHAIN ADJUSTER	2
8	N01S-08-06	TUERCA EJE TRASERO	REAR AXLE NUT	1
8-A	90985-1200010ZB	TUERCA DIN 985 M12 ZB (N02S)	NUT DIN 985 M12 ZB (N02S)	1
9	N01S-08-08	FRENO DE LLANTA 20"	BRAKE TYRE 20"	1
10	N01S-08-10	BUJE TRASERO	REAR HUB	1
11	N01S-08-11	RADIO RUEDA TRASERA 20"	SPOKE - NIPPLE REAR WHEEL 20"	32
12	N01S-08-00	CONJUNTO LLANTA TRASERA 20"	REAR RIM 20" SET	1
13	N01S-09-05	DISCO DE FRENOS TRASERO 140	REAR DISK BRAKE 140	1
14-A	90125-1200008ZB	ARANDELA DIN 125 M12 ZB (N02S)	WASHER DIN 125 M12 ZB (N02S)	2
15	90912-0501608ZB	TORNILLO DIN 912 M5x16 ZB	SCREW DIN 912 M5x16 ZB	6
16	97380-05010A2IN	TORNILLO ISO 7380 M5x10 IN	SCREW ISO 7380 M5x10 IN	6

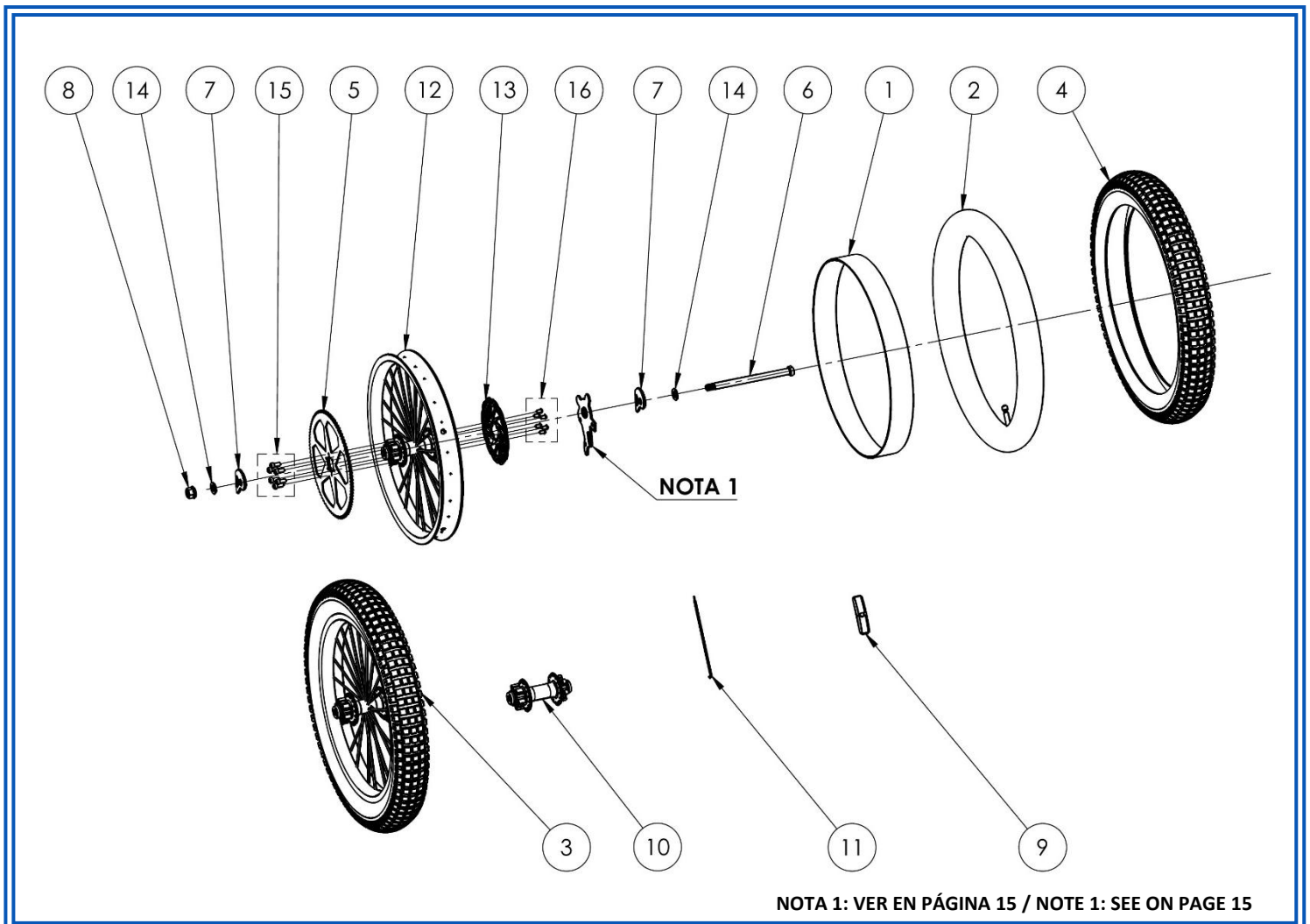

NOTA 1: VER EN PÁGINA 15 / NOTE 1: SEE ON PAGE 15

SEC 10	FRENO DELANTERO	FRONT BRAKE
---------------	----------------------------	--------------------

Nº	REF.	DESCRIPCIÓN	PARTS NAME	QTY
1	N01S-09-04	CONJUNTO PASTILLAS DE FRENO	BRAKE PADS SET	1
2	N01S-10-01	CONJUNTO FRENO DELANTERO	FRONT SET BRAKE	1
3	N01S-10-05	BOMBA DE FRENO DERECHA	BRAKE PUMP RIGHT	1
4	N01S-10-18	MANETA DE FRENO	BRAKE LEVER	1

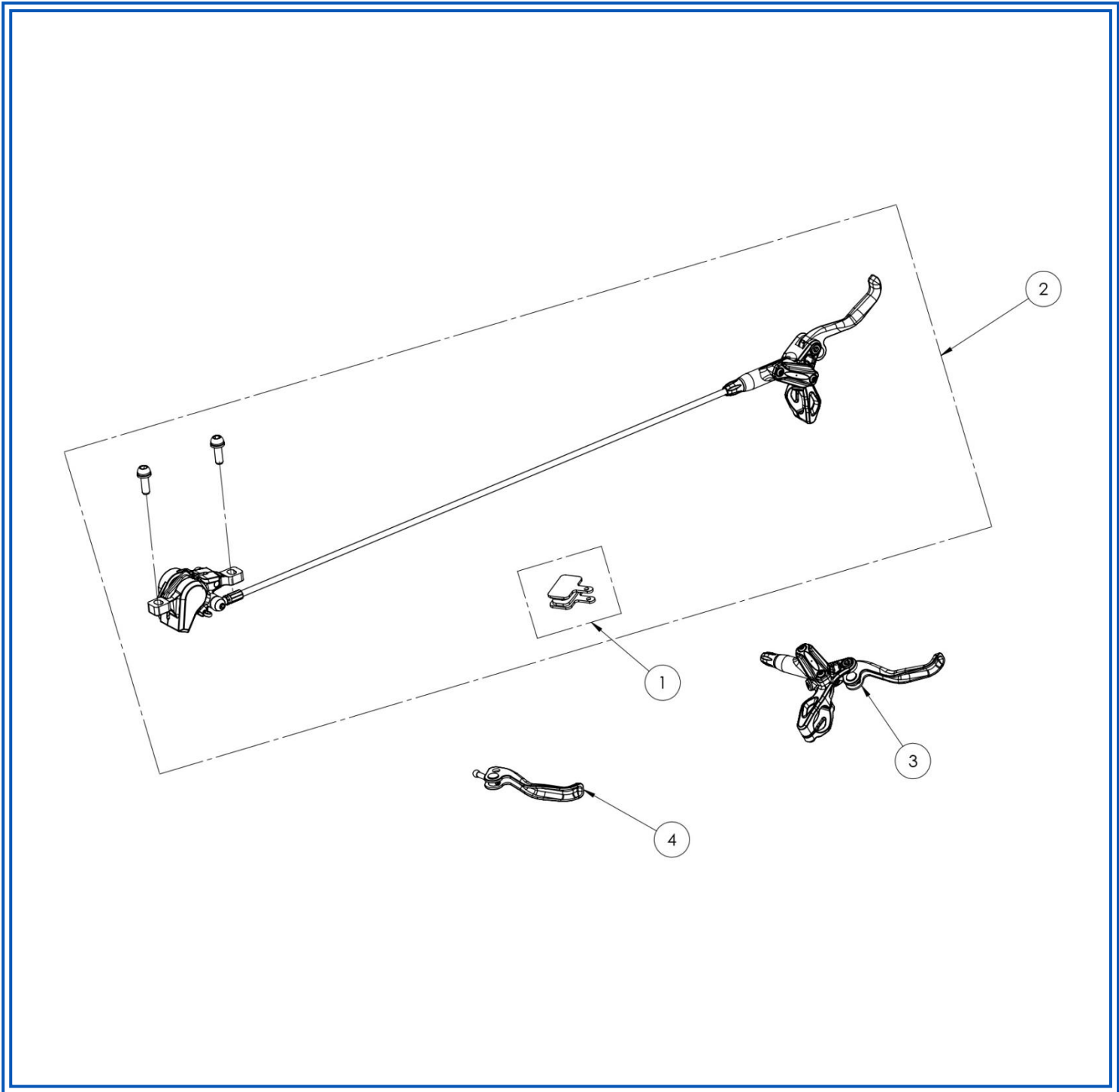

SEC 11
FRENO TRASERO
REAR BRAKE

Nº	REF.	DESCRIPCIÓN	PARTS NAME	QTY
1	N01S-09-01	CONJUNTO FRENO TRASERO	REAR SET BRAKE	1
2	N01S-09-02	BOMBA DE FRENO IZQUIERDA	BRAKE PUMP LEFT	1
3	N01S-09-04	CONJUNTO PASTILLAS DE FRENO	BRAKE PADS SET	1
4	N01S-09-06-PN	SOPORTE FIJACIÓN PINZA FRENO TRASERO	REAR STAY FIX CALIPER WELDING	1
5	N01S-09-09	ADAPTADOR PINZA FRENO TRASERO	ADAPTOR REAR CALIPER	1
6	N01S-09-10	GRAPA M6 FIJACIÓN PROTECTOR FRENO TRASERO	STAPLE M6 MIKALOS FIX REAR BRAKE PROTECTOR	1
7	N01S-12-26	CASQUILLO PROTECTOR DISCO FRENO TRASERO	REAR DISC BRAKE PROTECTOR COLLAR	1
8	N01S-10-18	MANETA DE FRENO	BRAKE LEVER	1
9	90912-0601608ZN	TORNILLO DIN 912 M6x16 ZN	SCREW DIN 912 M6x16 ZN	3

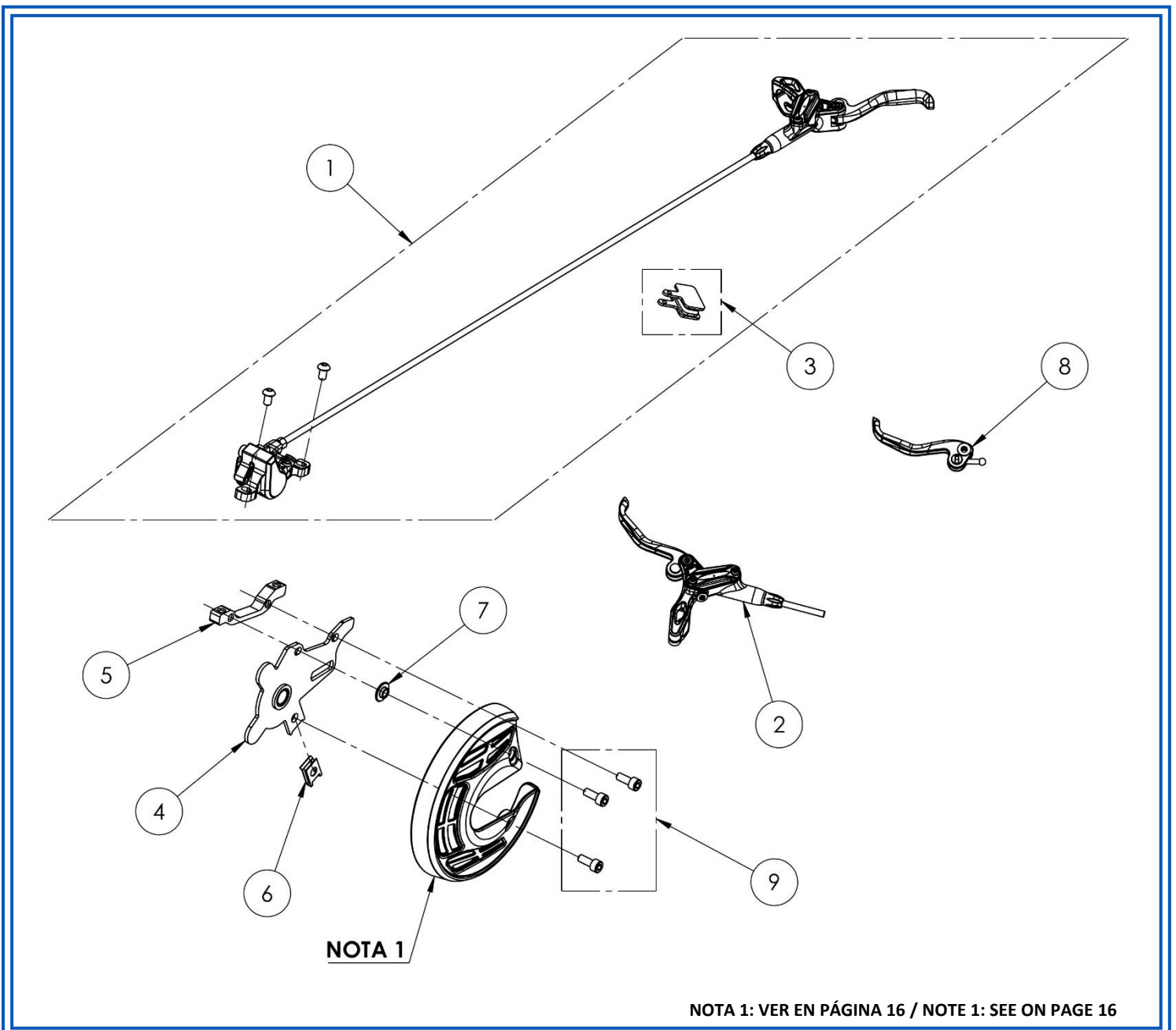

NOTA 1: VER EN PÁGINA 16 / NOTE 1: SEE ON PAGE 16

SEC 12
PLÁSTICOS
PLASTICS

Nº	REF.	DESCRIPCIÓN	PARTS NAME	QTY
1	N01S-02-05	PRENSAESTOPA	CABLE GLAND	1
2	N01S-06-03	CADENA DESLIZANTE	SLIDER CHAIN	1
3	N01S-08-07	PROTECTOR DE PIÑÓN FINAL	SPROCKET FINAL DRIVEN PROTECTOR	1
4	N01S-12-01	TAPA CENTRAL DE BATERÍA	TAPA CENTRAL BATERIA	1
5	N01S-12-02	GUARDABARROS TRASERO	GUARDABARROS TRASERO	1
6	N01S-12-03	GUARDABARROS DELANTERO	GUARDABARROS DELANTERO	1
7	N01S-12-04	PLACA PORTANÚMERO	PLATE NUMBER	1
8	N01S-12-05	PROTECTOR DE DISCO DELANTERO	FRONT DISK PROTECTOR	1
9	N01S-12-06	PROTECTOR DE DISCO TRASERO	REAR DISK PROTECTOR	1
10	N01S-12-07	CAJA DE ASIENTO	CAJA-ASIENTO	1
11	N01S-12-08	TAPA DE CAJA DE ASIENTO	COVER SEAT BOX	1
12	N01S-12-09-MC	CUBIERTA DE GOMA PARA CAJA DE ASIENTO (PEGADA)	RUBBER COVER SEAT BOX (GLUE)	1
13	N01S-12-10	CASQUILLO FIJACIÓN CAJA ASIENTO A CHASIS	COLLAR FIX BOX SEAT TO FRAME	2
14	N01S-12-11	CASQUILLO FIJACIÓN CAJA ASIENTO A GUARDABARROS TRASERO	COLLAR FIX BOX SEAT TO REAR FENDER	3
15	N01S-12-12	SOPORTE DE GOMA PARA VOLTÍMETRO	RUBBER FIX VOLTAGE METER	1
16	N01S-12-13	PROTECTOR DE GOMA AMORTIGUADOR TRASERO	RUBBER PROTECTOR REAR SHOCK ABSORBER	1
17	N01S-12-16	TORNILLO DZUS DE FIJACIÓN	DZUS BOLT FIX	1
18	N01S-12-17	ARANDELA DZUS	WASHER DZUS	1
19	N01S-12-19	PROTECTOR DE BARRO DELANTERO DE CHASIS	FRONT FRAME MUD PROTECTOR	1
20	N01S-12-20	CASQUILLO LATERAL FIJACIÓN CAJA ASIENTO A CHASIS	SIDE COLLAR FIX BOX SEAT TO FRAME BODY	1
21	N01S-12-21	GOMA TAPA CENTRAL DE BATERÍA	RUBBER CENTRAL COVER BATTERY	2
22	N01S-12-22	PROTECTOR DE CADENA DEL MOTOR	CHAIN ENGINE PROTECTOR	1
23	N01S-12-25	GOMA DE CAJA DE ASIENTO	SEAT BOX RUBBER	2
24	N01S-12-27	CASQUILLO LATERAL FIJACIÓN CAJA ASIENTO A CHASIS	SIDE COLLAR FIX BOX SEAT TO FRAME BODY	1
25	N01S-12-30	TAPA DE CAJA ELECTRÓNICA	ELECTRONIC BOX COVER	1
26	N01S-12-31	BASE DE CAJA ELECTRÓNICA	ELECTRONIC BOX BASE	1
27	N01S-12-32	ARANDELA DE NYLON	NYLON WASHER	1
28	N01S-12-35	ETIQUETA PROTECTOR DE BARRO DELANTERO DE CHASIS	FRONT FRAME MUD PROTECTOR LABEL	2
29	N01S-90-07	BRIDA 4,8x188 (NEGRA)	TIE BAND 4,8x188 (BLACK)	2
30	90POE-0501608ZB	TORNILLO TORN POELIER M5x16 ZB	SCREW TORN POELIER M5x16 ZB	1
31	90POE-0602508IN	TORNILLO TORN POELIER M6x25 INOX	SCREW TORN POELIER M6x25 INOX	3
32	90125-0400008ZB	ARANDELA DIN 125 M4 ZB	WASHER DIN 125 M4 ZB	2
33	96921-0603008ZB	TORNILLO DIN 6921 M6x30 ZB	SCREW DIN 6921 M6x30 ZB	2
34	96923-0600008ZB	TUERCA DIN 6923 M6 ZB	NUT DIN 6923 M6 ZB	3
35	97981-040008081IN	TORNILLO DIN 7981 3,9x8 PUNTA F INOX	SCREW DIN 7981 3,9x8 POINT F INOX	2
36	99021-0600008ZB	ARANDELA DIN 9021 M6 ZB	WASHER DIN 9021 M6 ZB	2

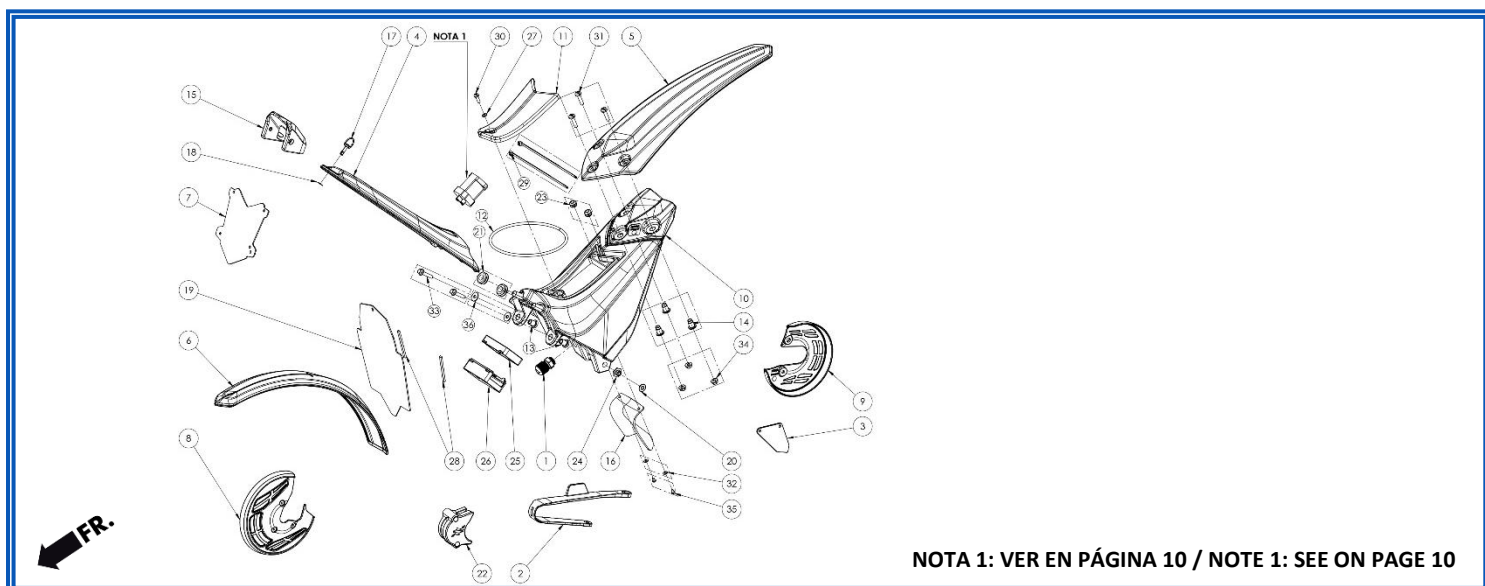

SEC 13	ADHESIVOS ADVERTENCIA	WARNING LABELS
---------------	----------------------------------	---------------------------

Nº	REF.	DESCRIPCIÓN	PARTS NAME	QTY
1	N01S-13-05	ETIQUETA DE SEGURIDAD	SAFETY LABEL	1
2	N01S-13-06	ETIQUETA DE INFORMACIÓN	INFORMATION LABEL	1
3	N01S-13-08	ETIQUETA INFORMACIÓN BATERÍA	INFORMATION BATTERY LABEL	1
4	N01S-13-09	ETIQUETA CE	CE LABEL	1
5	N01S-13-10	ETIQUETA INFORMACIÓN CONTROLADORA	INFORMATION CONTROLLER LABEL	1

1

2

3

4

5

6

7

SEC 14	ADHESIVOS NEUTRA K3	NEUTRA K3 LABELS
---------------	--------------------------------	-----------------------------

Nº	REF.	DESCRIPCIÓN	PARTS NAME	QTY
1	N01S-13-01	CONJUNTO ADHESIVOS NEUTRA 20" 2025	SET LABELS NEUTRA 20" 2025	1
2	N01S-13-02	ADHESIVO MAPAS	MAP LABEL	1
3	N01S-13-03	CONJUNTO ADHESIVOS LLANTAS NEUTRA 20" 2025	RIMS LABELS PLASTICS NEUTRA 20" 2025	1
4	N01S-13-04	CONJUNTO ADHESIVOS BATERÍA	BATTERY LABELS PLASTICS SET	1

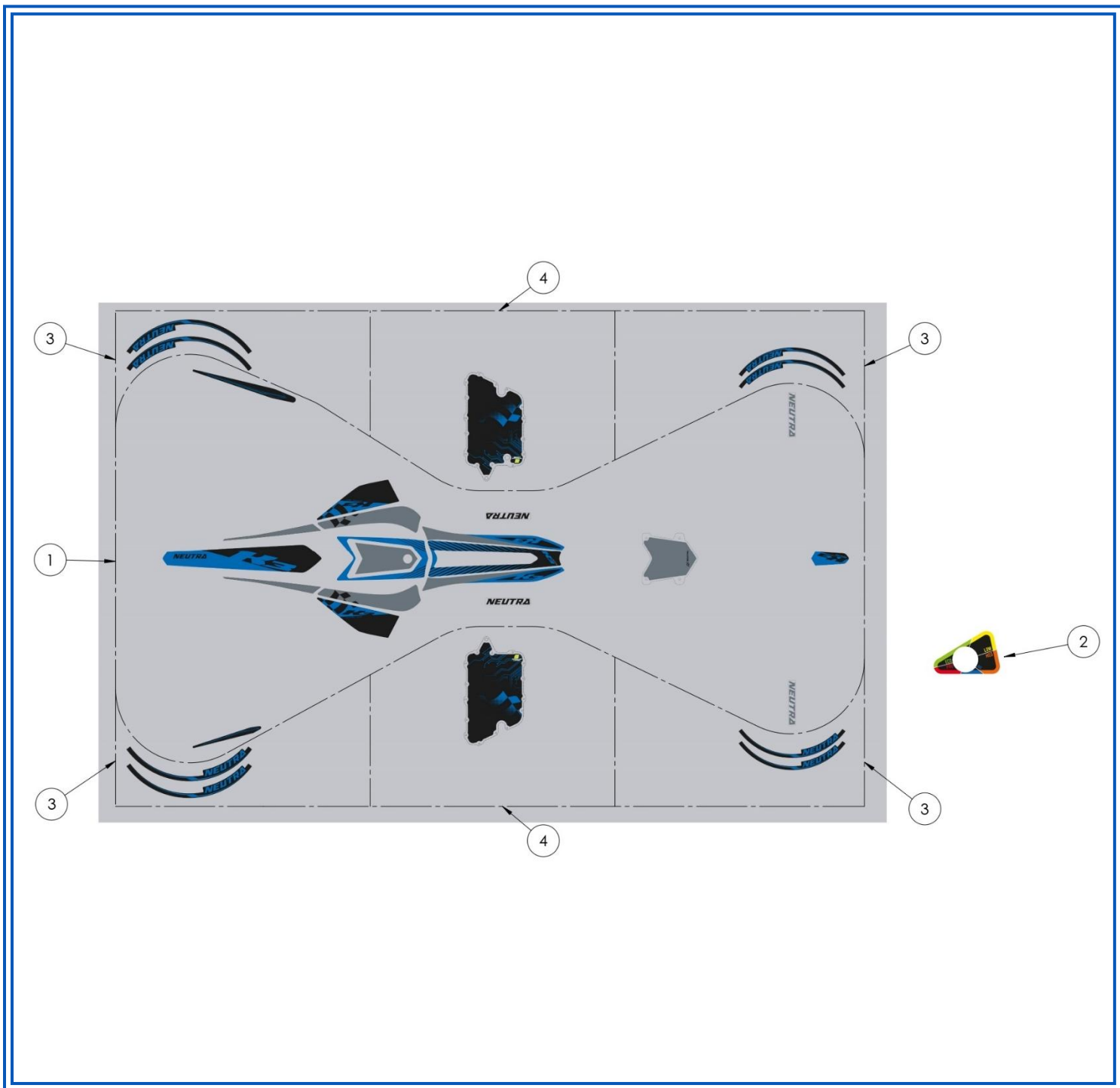

SEC 15	ACCESORIOS	ACCESSORIES
---------------	-------------------	--------------------

Nº	REF.	DESCRIPCIÓN	PARTS NAME	QTY
1	N01S-06-02-M2	AMORTIGUADOR TRASERO DE AIRE	REAR SHOCK ABSORBER AIR	1
2	N01S-14-01	MUELLE DE 350 LBS	350 LBS SPRING	1
3	N01S-14-02	MUELLE DE 550 LBS	550 LBS SPRING	1
4	N01S-14-05	MANCHA SUSPENSIÓN DELANTERA	FRONT SUSPENSION STAIN	1
5	N01S-14-09	PROTECTOR INFERIOR SUSPENSIÓN DELANTERA	FRONT SUSPENSION LOWER PROTECTOR	1
6	N01S-14-10	CASQUILLO PROTECTOR INFERIOR SUSPENSIÓN DELANTERA	COLLAR FRONT SUSPENSION LOWER PROTECTOR	1
7	N01S-14-33	PROTECTOR INFERIOR BASTIDOR REFORZADO	REINFORCED PLATE SKID	1

**CUIDADO! Para la primera compra, si elige el componente 5 o 6, es necesario solicitarlos conjuntamente para garantizar un montaje correcto.*

**CAUTION! For the first purchase, if you choose component 5 or 6, it is necessary to order them together to ensure proper assembly.*

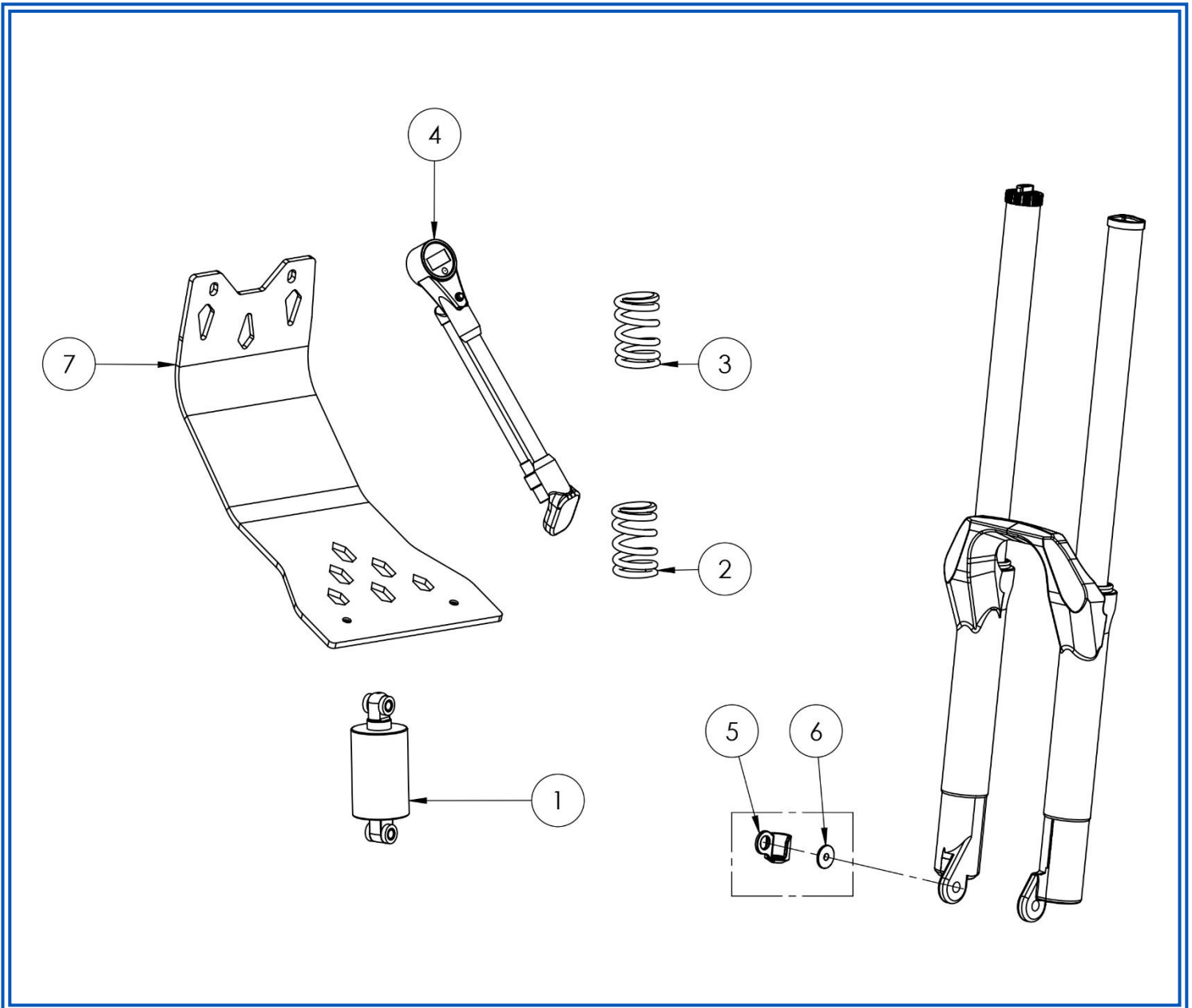

SEC 15
ACCESORIOS
ACCESSORIES

Nº	REF.	DESCRIPCIÓN	PARTS NAME	QTY
8	N01S-01-01	BATERÍA STD (50,4V 16,8Ah)	BATTERY STD (50,4V 16,8Ah)	1
9	N01S-01-41	BATERÍA GRANDE (50,4V 21Ah)	LARGE BATTERY (50,4V 21Ah)	1
10	N01S-01-61	BATERÍA COMPACTA (50,4V 12,6Ah)	COMPACT BATTERY (50,4V 12,6Ah)	1
11	N01S-02-04-M4	CARGADOR DC 51V 10A (EU)	CHARGER DC 51V 10A (EU)	1
12	N01S-14-04	FRENO NEUMÁTICO TRASERO 20"	20" REAR BRAKE TIRE	1
13-A	N01S-14-07-SI	ADHESIVO SUPERIOR DEL CHASIS LADO IZQUIERDO	UPPER FRAME LABEL LEFT SIDE	1
13-B	N01S-14-07-SD	ADHESIVO SUPERIOR DEL CHASIS LADO DERECHO	UPPER FRAME LABEL RIGHT SIDE	1
13-C	N01S-14-07-II	ADHESIVO INFERIOR DEL CHASIS LADO IZQUIERDO	LOWER FRAME LABEL LEFT SIDE	1
13-D	N01S-14-07-ID	ADHESIVO INFERIOR DEL CHASIS LADO DERECHO	LOWER FRAME LABEL RIGHT SIDE	1
14	N01S-14-11	INDICADOR DE BATERÍA EXTERNO	EXTERNAL BATTERY INDICATOR	1
15	N01S-14-34-PN	ESTRIBERA DERECHA EXTRA	EXTRA BRACKET STEP R	1
16	N01S-14-35	HERRAMIENTA FIJACIÓN EJE DEL BASCULANTE	SWINGARM SHAFT FIXING TOOL	1
17	N01S-14-39	HERRAMIENTA COMPROVADOR TENSIÓN CADENA	CHAIN TENSIONER TOOL	1
18	N01S-14-40-PN	SOPORTE GUARDABARROS DELANTERO RACING	FRONT FENDER SUPPORT RACING	1
19	N01S-14-54-PN	ESTRIBERA IZQUIERDA EXTRA	EXTRA BRACKET STEP L	1
20	N01S-14-55	PROTECTOR DE CADENA	CHAIN GUARD	1
21	N01S-14-58	PIÑÓN Z12 MOTOR ELÉCTRICO	SPROCKET 12Z ELECTRIC ENGINE	1
22	N01S-14-59	PROTECTOR PIÑÓN Z12	CHAIN ENGINE PROTECTOR 12Z	1
23	N01S-14-60	ADHESIVO EXTRA CORONA	EXTRA ADHESIVE FINAL DRIVE SPROCKET	1

**CUIDADO! Para la primera compra, si elige el componente 15 o 19, es necesario solicitarlos conjuntamente para garantizar un montaje correcto.*

**CUIDADO! Para la primera compra, si elige el componente 21, es necesario solicitarlos conjuntamente con el 22 para garantizar un montaje correcto.*

**CAUTION! For the first purchase, if you choose component 15 or 19, it is necessary to order them together to ensure proper assembly.*

**CAUTION! For the first purchase, if you choose component 21, it must be ordered together with component 22 to ensure proper assembly.*

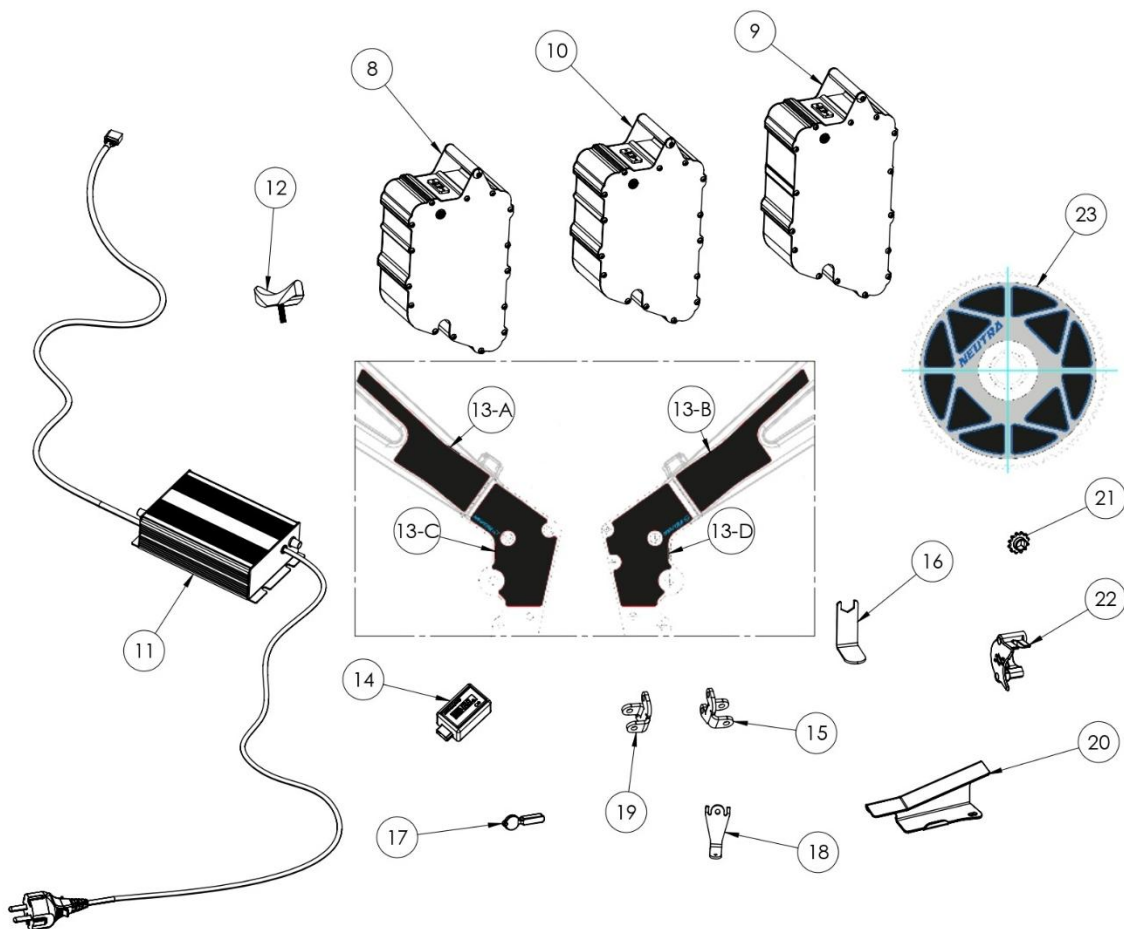

SEC 15
ACCESORIOS
ACCESSORIES

Nº	REF.	DESCRIPCIÓN	PARTS NAME	QTY
24	N01S-14-06	MANETA DE FRENO EXTRA	EXTRA BRAKE LEVER	1
25	N01S-14-19	CONJUNTO COMPLETO DE ASIENTO	TOTAL SET SEAT	1
26	N01S-14-27	CONJUNTO COMPLETO DE FRENO TRASERO DE PIE	TOTAL SET REAR BRAKE	1
27	N01S-14-28-PN	SOPORTE TRASERO FIJACIÓN PINZA FRENO DE PIE	REAR STAY FIX CALIPER WELDING	1
28	N01S-14-36	POMO DEL ASIENTO	HANDLE	1
29	N01S-14-41	ASIENTO	SEAT	1
30	N01S-14-42	CONJUNTO SOPORTES FIJACIÓN ASIENTO	SET SUPPORTS SEAT	1
31	N01S-14-43	CONJUNTO PINZA-BOMBA DE FRENO DE PIE	SET BRAKE CALIPER-PUMP	1
32	N01S-14-44	CONJUNTO PALANCA DE FRENO DE PIE	SET LEVER	1
33	N01S-14-45	CONJUNTO PASTILLAS DE FRENO TRASERO DE PIE	SET BRAKE PADS	1

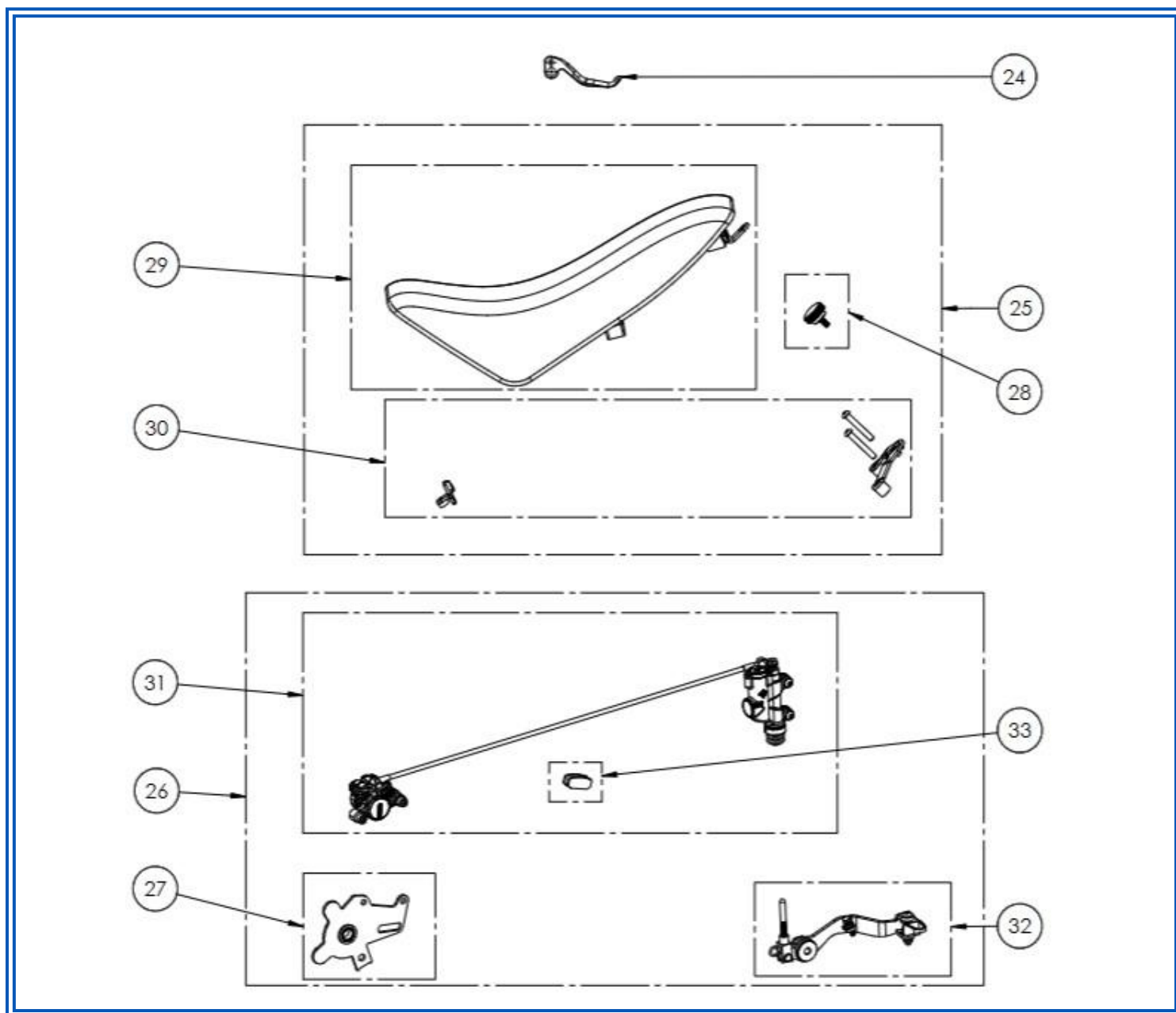

SEC 15
ACCESORIOS
ACCESSORIES

Nº	REF.	DESCRIPCIÓN	PARTS NAME	QTY
34	N01S-05-15	TAPÓN DE AJUSTE DE PRECARGA - SUSPENSIÓN DE AIRE	PRELOAD ADJUSTMENT CAP – AIR SUSPENSION	1
35	N01S-05-16	TAPÓN DE AIRE - SUSPENSIÓN DE AIRE	AIR CAP - AIR SUSPENSION	1
36	N01S-05-17	BARRA DE AIRE - SUSPENSIÓN DE AIRE	AIR BAR - AIR SUSPENSION	1
37	N01S-05-18	BARRA DE MUELLE - SUSPENSIÓN DE AIRE	SPRING BAR - AIR SUSPENSION	1
38	N01S-05-19	AJUSTADOR DE EXTENSIÓN HIDRÁULICA - SUSPENSIÓN DE AIRE	HYDRAULIC EXTENSION ADJUSTER - AIR SUSPENSION	1
39	N01S-05-20	SELLO EXTERIOR - SUSPENSIÓN DE AIRE	OUTER SEAL - AIR SUSPENSION	1
40	N01S-05-21	CONJUNTO DE BARRA DE AIRE INTERIOR - SUSPENSIÓN DE AIRE	INNER AIR BAR ASSEMBLY - AIR SUSPENSION	1
41	N01S-05-22	CASQUILLO DE FRICCIÓN DE BARRA DE AIRE - SUSPENSIÓN DE AIRE	AIR BAR FRICTION COLLAR - AIR SUSPENSION	1
42	N01S-05-23	REGULADOR INTERNO DE MUELLE - SUSPENSIÓN DE AIRE	INTERNAL SPRING REGULATOR - AIR SUSPENSION	1
43	N01S-05-24	JUNTA TÓRICA - SUSPENSIÓN DE AIRE	O-RING - AIR SUSPENSION	1

