



TECHNICAL MANUALS
K5/KOUNTRY5

INTRODUCTION

You must read this technical manual carefully before riding the motorcycle and make your children understand the precautions and safety measures that must be taken.

Before using the K5/KOUNTRY5 motorcycle, you must make sure that you have understood everything written in this manual, paying particular attention to the warnings and safety section.

This manual must always be carried with the motorcycle and must be transferred in any change of ownership.



Before using the motorcycle, you must read this manual carefully and keep it for future reference.

If you have any questions, you can go to your NEUTRA point of sale or you can contact the official distributor on our website.

You can also write to us by email and our staff will respond as soon as possible.

This manual contains important safety, operation, assembly and preparation information for the correct use of the motorcycle.

The motorcycle is not ready for immediate use, it arrives partially assembled.

You must follow the assembly and preparation procedures indicated in this manual for good motorcycle safety.

You must also take into account the safety information explicit in this manual, to avoid personal injury when assembling and maintaining it.

Where to find safety information:

- Safety labels on the motorcycle.
- Warning symbols together with a word and instructions or information that you should consider, which you can find in this manual.

 **DANGER:**

A hazardous situation that may result in death or serious injury.

 **WARNING:**

A hazardous situation that may result in death or serious injury.

 **CAUTION:**

Information on practices that do not involve risk of injury. It is used to prevent damage to the motorcycle or the environment.

This manual also includes the following information:

NOTICE:

Information to assist you in the operation or maintenance of your motorcycle.

This publication contains the latest motorcycle information available prior to publication.

NEUTRA reserves the right to make changes at any time without notice and without incurring any obligation.





CHARGER MANUAL
K5/KOUNTRY5

Ver.1.0 FEB-26

TABLE OF CONTENTS

1	GENERAL.....	3
2	DANGERS AND WARNINGS	3
3	CHARGING THE BATTERY	4
4	CHARGER STORAGE	6
5	TRANSPORT.....	6
6	SPARE PARTS.....	6
7	FEATURES.....	7
8	TROUBLESHOOTING	11



1 GENERAL

The battery charger, 210 x 100 x 68 mm can work normally with 58.8 VDC and 10/15 A.

Component list:

Charger: 1 unit.

DC cables with direct wire.

AC power cable with direct wire.

2 DANGERS AND WARNINGS

Sparking phenomenon is normal when connected to the battery due to high current. You must make sure that the charger type matches the battery type before charging. Always place the charger in a well-ventilated and dry environment.

WARNING

The battery must be charged in conditions of humidity below 75% and a temperature between 0°C and 40°C.

Do not cover it to prevent the case from overheating during charging.

Do not touch the charger while charging the battery, it is an element that can heat up.

To avoid possible burns, wait until it has cooled down.

DANGER

- The interior of the equipment cannot be accessed, never open the charger system. Any attempt to open it will void the warranty.
- DO NOT charge the battery with the ignition switch in the ON position.
- Risk of electric shock. Do not touch the uninsulated part of the connectors.
- Do not expose to fire.
- Prevent entry and do not immerse the charger in any liquid.
- Do not hit or drop the charger.
- Keep the charger and battery away from children during the charging process.

DANGER

Specific training and tools are required to work with electrical systems, as there is a risk of electric shock when working under voltage.

Under no circumstances should any electrical or electronic component of the motorcycle be opened.

CAUTION

It is forbidden to use any charger that is NOT supplied by the manufacturer.

WARNING

If signs of deterioration or any type of imperfection are observed in the charging elements, they must be replaced. You must ensure that all electrical connectors are in good working order.



To do so, go to your NEUTRA point of sale or you can contact the official distributor on our website.

You can also write to us at our email address and our staff will respond as soon as possible.

3 CHARGING THE BATTERY

The following components are required to charge the K5/KOUNTRY5 battery:

Standard Battery (Fig. 1). Medium Battery (Fig. 2).

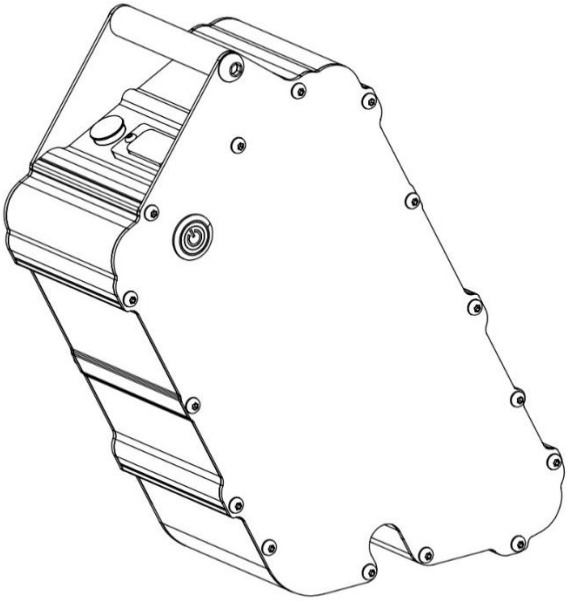

Fig. 1

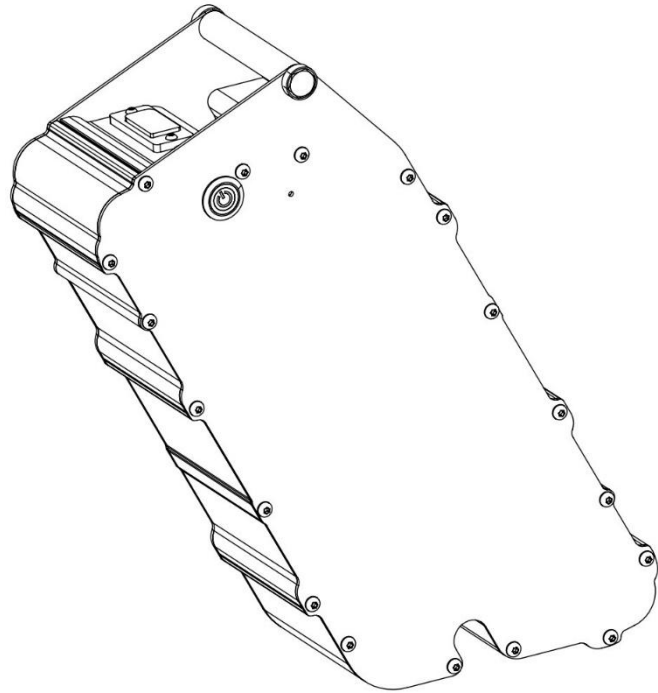

Fig. 2

Charger (Fig. 3).

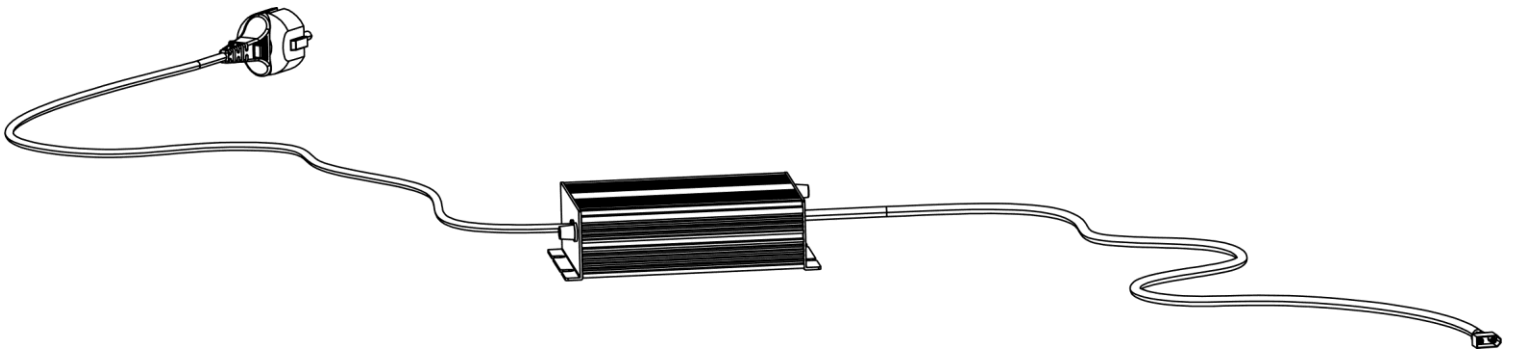

Fig. 3

You must follow the instructions below when using the charger to charge the battery.

NOTICE

FULLY CHARGE THE BATTERY BEFORE USING THE MOTORCYCLE.



1. You must plug the charger cable into the household plug (Fig. 4a). At this point, LED 1 on the charger will be red and LED 2 will be green (Fig. 5).
2. Next, you must connect the charger cable with its two-pin connection to the battery. You must correctly position the two-pin plug (Fig. 4b) by aligning it with the slot and insert it.

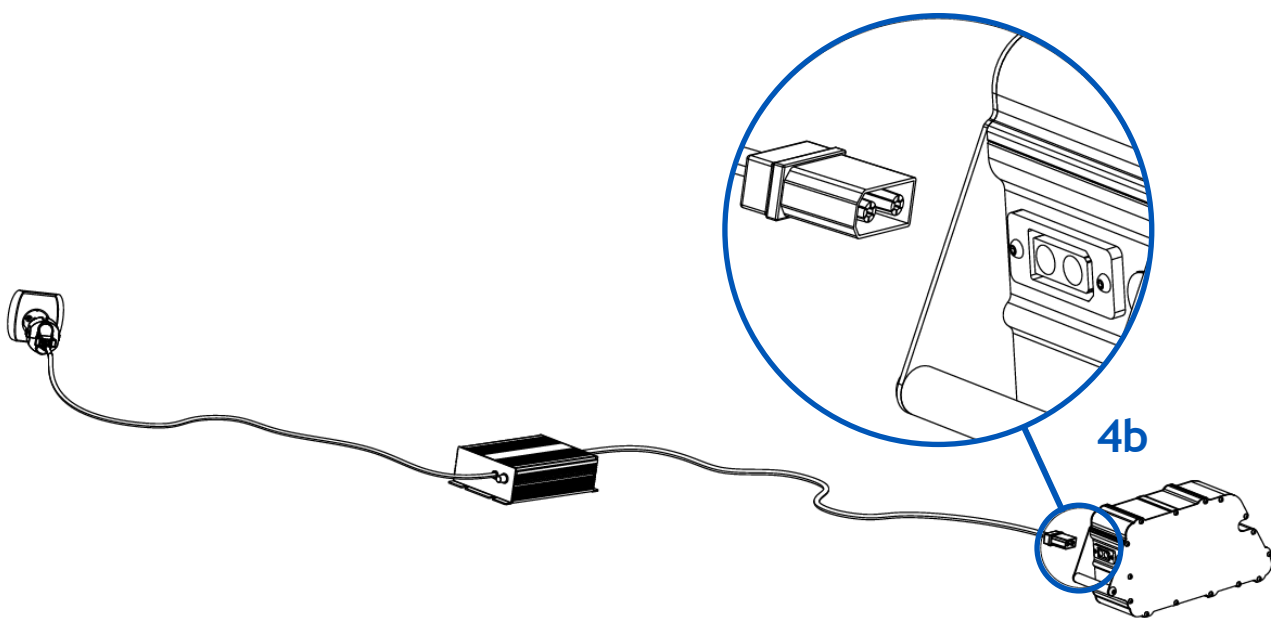

Fig. 4a and 4b

You will notice that both LEDs on the battery charger will be red, which means that the battery is charging correctly.

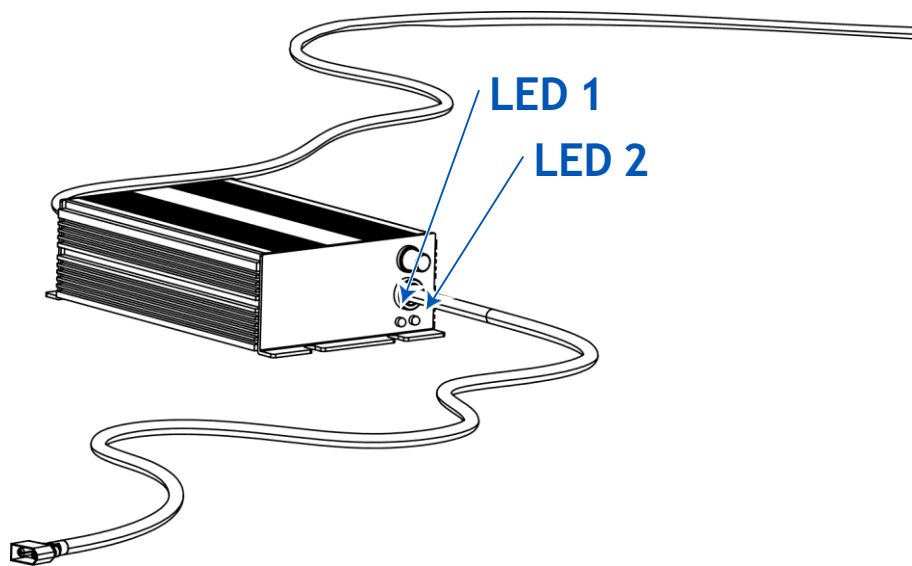

Fig. 5

The battery will be fully charged in approximately 2 hours. You will know that the battery is fully charged when LED 1 on the charger is red and LED 2 is green.

Below, we can see a table indicating the colors of the two LEDs on the battery charger according to the different states:

	LED 1	LED 2
CHARGER ON	●	●
BATTERY CHARGING	●	●
BATTERY CHARGED	●	●

To extend the life of the battery, you should avoid half-charging.

Once the battery is fully charged, you should follow these steps to be able to use the vehicle.

You should disconnect the battery charger, then unplug the charger from the household power outlet and store the battery charger in its corresponding box.



CAUTION

You should always disconnect the cables by the rigid part of the connectors, you should never disconnect them from the charger by pulling on the cables, or should you connect them with excessive force.

It is forbidden to use any charger that is NOT supplied by the manufacturer.

WARNING

If you notice signs of deterioration or any type of imperfection in the battery or the charging elements, they must be replaced.

To do so, go to your NEUTRA point of sale or you can contact the official distributor on our website. You can also write to us at our email and our staff will respond as soon as possible.

4 CHARGER STORAGE

You must consider the aspects mentioned below, to store the charger correctly for a long period of time.

CAUTION

- Place the charger in a clean, dry and well-ventilated place.
- Avoid direct sunlight.
- Keep away from heat sources.
- The temperature must remain between -10°C and +40°C.
- The humidity must be between 5% and 95%.
- There must be no harmful gases, flammable products, explosives or corrosive chemicals in the warehouse.
- The package box must be at least 20 cm high above the ground and 50 cm away from the wall, heat source and ventilation.
- According to this requirement, the product has a storage period of 2 years and must be re-checked when it exceeds 2 years.

5 TRANSPORT

- Suitable for truck transport.
- Products must be protected and loaded or unloaded carefully.

6 SPARE PARTS

WARNING

You must always use original NEUTRA spare parts.



7 FEATURES

7.1- Electrical specifications

7.1.1- Main product specification

	Technical specifications
Maximum output voltage	58.8 V
Output current	10 A/15 A
Max. Output power	588 W/882 W
Input voltage	180 ~ 260 Vac
Shut off	0.5 A

7.1.2- Input characteristics

	Technical specifications
Nominal input voltage	220 Vac
Input voltage range	180 ~ 260 Vac
AC input voltage frequency	50 ~ 60 Hz

7.1.3- Output characteristics or charging stages

	Technical specifications	Remarks
CC (constant current)	10 A/15 A	-
CV (constant voltage)	58.8 Vdc, ↓	-
Energy efficiency	≥88%	110 Vac / 220 Vac, Vin=110 Vac / 220 Vac Nominal load

7.1.4- Protection Features

	Technical specifications	Remarks
Over voltage protection	Yes	-
Over voltage protection software	The charger software limits the maximum output voltage to a level suitable for the connected battery system.	-
Thermal protection	Aluminum housing internal temperature > 75°C, automatic shutdown.	-
Current limiting protection	Yes	In DC mode
Short circuit protection	The short circuit protection should automatically recover after the condition is removed.	-
Reverse polarity protection	When the output cables are connected backwards to the battery, the charger will not operate and will operate normally when the DC cables are connected correctly.	-
IP	IP 33	Silica resin



7.1.5- Charging Indicator

	Status
Power	LED1: Red
Charging	LED2: Red
Fully Charged	LED2: Green
Charging Voltage Display	No
Charging Current Display	No

7.2- Environmental Conditions

	Technical Specifications
Operating Temperature	-10 ~ +40°C
Humidity	5 ~ 95%
Storage Temperature	-10 ~ +40°C
Altitude	0 ~ 3000m
Cooling	Forced Air Cooling

7.3- Safety and Electromagnetic Compatibility

		Standard Remarks (Test Condition)	Remarks
Electrical Strength Test	Input-Output	1500 Vac / 1 min ≤ 10 mA	Must be able to withstand voltage of 1500 V, 1 minute, leakage current ≤ 5 mA, no breakdown or phenomenon Arcing
	Input-Ground		
Insulation Resistance	Input-Output	≥ 10 MΩ a 500 Vac	Input to output, input to enclosure 500 Vdc and normal air pressure, tested at 90% relative humidity
	Output-Enclosure		
EMI	Conducted	EN55014 EN55022	150 k ~ 30 MHz
	Radiated	EN55014 EN55022	30 MHz ~ 1 GHz
	Power Clamp	EN55014 EN55022	30 MHz ~ 1 GHz
Safety	CE		

7.4- Environmental Test Requirements

	Technical Specifications	Remarks
High Temperature Operating Environment	+40°C	Features OK
Low Ambient Temperature Operating	-10°C	Features OK
High Temperature Storage	+40°C	Should be stored normally after recovery at room temperature for 2 hours
Low Temperature Storage	-40°C	40°C It should be stored normally after recovery at room temperature for 2 hours



7.5- Mechanical characteristics

	Technical specifications	Size
Housing material	Aluminium	208*100*68 mm
Input socket	European standard	AC cable is 1.5 meters long
Output socket	50 A	DC line 1.5 meters
Net weight	2 Kg	-
Case color	Black and silver	

7.6- Overcharge protection

Automatically shuts off when the battery is fully charged. Prevents battery explosion due to overcharging.

Greatly improves the safety of the charging process.

Tailor-made charging way and speed, such as pre-charge and adjusted bulk charge.

The best charging way tailored for your battery.

Please see the following pictures of the charging curve for your reference.

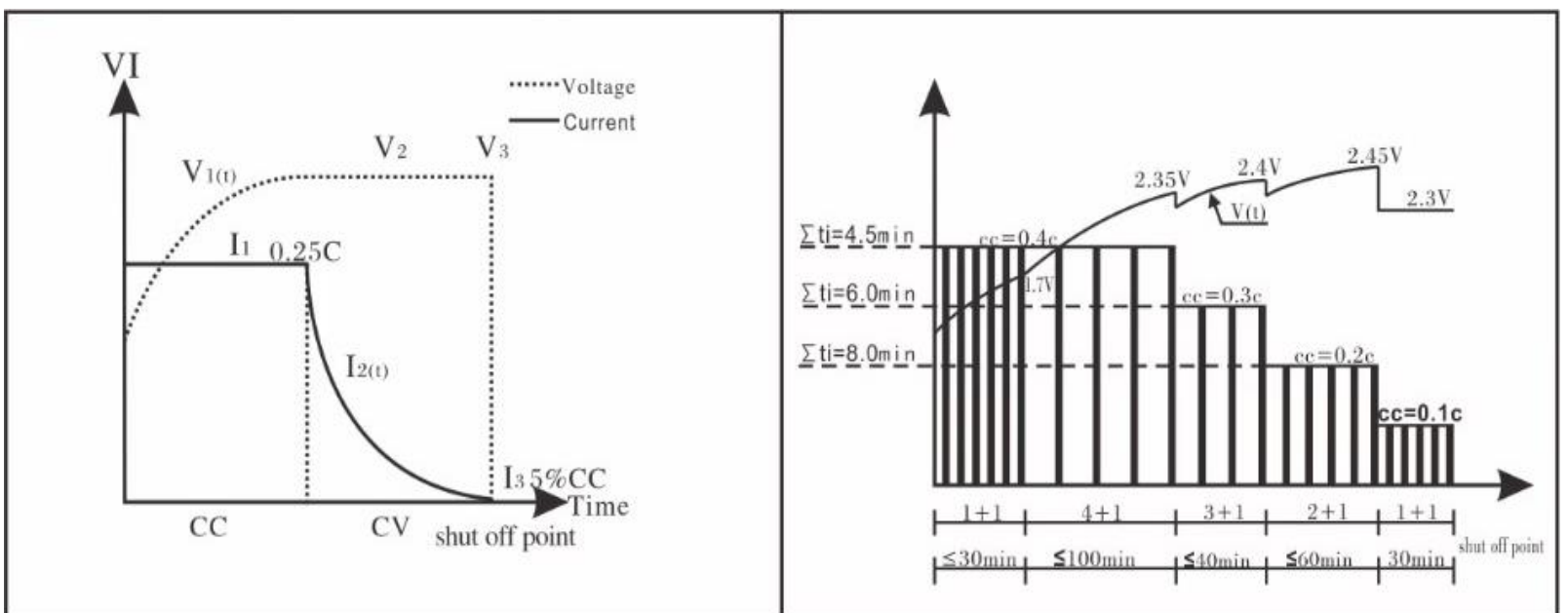

Fig. 6

7.7- Features

1. Protections against reverse polarity, over-current, over-voltage, short circuit and preventing current from flowing backward.
2. The charger has an over-heat protection function. The internal temperature reaches 75°C (rising state). The whole machine will automatically shut down. It will be in standby mode or working in a high temperature environment. There will be repeated pauses for 5-10 seconds and then work will resume. This will prolong the charging time. At this time, external auxiliary heat dissipation measures can be taken. When the temperature drops to 40°C, charging will automatically restart.



7.8- Operations

1. Confirm whether the battery type and specifications match those of the battery, and check whether the local AC voltage matches the input voltage of the charger.
2. Connect the battery according to the positive and negative poles first and then connect the AC input plug of the charger. After the battery is connected, the charger indicator turns red and the other turns green. If the LED indicators are all red after the battery is connected, the charger is already in charging status.
3. When the charging status LED2 indicator turns green, it means that the battery is fully charged and the charger has stopped outputting. You can disconnect the input and output connectors.

NOTICE

If the rechargeable battery is in over-discharge and under-voltage status, it is necessary to connect the AC output trigger relay first and then connect the battery to charge it.

CAUTION

This charger is not waterproof or dustproof. Please only store and use the charger in a dry and dust-free environment.

Please do not store and use under direct heat/radiation or near heat/radiation source.

Charging in humid, dusty or unventilated environments may cause damage to the charger and battery.

Do not block the charger's ventilation/cooling channels and keep a minimum distance of 10cm between any obstruction and the wind channels (or the front and back panels where the wind inlet and outlet are located).

Do not cover the charger. Keep the charger out of reach of children.

If a two-pin AC plug is used, the charger housing must be connected with a ground wire of 2.5mm² or higher.



8 TROUBLESHOOTING

If the charger does not work properly, check the following: Are the battery and charger connected properly?

Is the voltage level appropriate? Is the charger in protected state?

Does the charger enter over-temperature or over-current protection state? After the problem is solved, please disconnect the AC power for a few seconds and reconnect it.

If the charger still does not work properly, please contact the dealer immediately. For that, please go to your NEUTRA outlet or you can contact the official dealer on our website. You can also write to us at our email and our staff will reply to you as soon as possible.

Do not attempt to repair the charger without technical assistance from the dealer or manufacturer.

Error input voltage: Check whether the input voltage meets the requirement or not.

Abnormal AC input: Check whether there is AC voltage and whether the input plug is loose.

Over-heated machine: Check whether the fan is working. Also pay attention to the ventilation at the charger's working place, covering the charger is not allowed.

Output short circuit: Check the cable line of the output terminal to rule out a short circuit.

No battery or reverse connection: Check the battery connection, connect the battery correctly.

Battery voltage is too low: Increase the battery voltage to the charger's starting voltage.

For any faults beyond those mentioned, please contact the dealer or manufacturer for technical support. For that, please go to your NEUTRA point of sale or you can contact the official dealer on our website. You can also write to us at our email and our staff will reply to you as soon as possible.

Do not unplug and insert the input plug several times, otherwise the thermistor may overheat and cannot cool down and be damaged, which will affect the normal use of the charger.

Opening the charger housing without the prior written consent of the manufacturer immediately voids the manufacturer's warranty.

Please be sure to charge the battery for half an hour at least every 3 months.

